



Catalogue
Series 9000 C-Truck fittings



Solutions for mobile automation

C_Transport

The transport sector is growing continuously and being driven by a demand for solutions that are increasingly complex and unique. Camozzi realized its own internal C_Transport division, in which technicians and Business Development Managers work in partnership with the client to study the applications even in environmental conditions which are characterized by extreme pressures or temperatures, in which external stress may affect the performances of the components.

The range of Series 9000 C-Truck fittings has been designed and developed to ensure high reliability and safety in the pneumatic braking systems on industrial and commercial vehicles.



Series 9000 C-Truck fittings

Mod. 9512 Page 4 	Mod. D6512 Page 5 	Mod. 9510 Page 5 	Mod. 9463 Page 5 	Mod. 9502 Page 6 	Mod. 9500 Page 7 	Mod. 9412 Page 7 	Mod. 9410 Page 7 
Mod. 9422 Page 8 	Mod. 9420 Page 8 	Mod. 9580 Page 9 	Mod. 9590 Page 9 	Mod. 9592 Page 9 	Mod. 9540 Page 10 	Mod. D2512 D2502 Page 10 	Mod. D2022 Page 10 
Mod. D2062 Page 11 	Mod. D2072 Page 11 	Mod. D2003 Page 11 	Mod. 9450 Page 12 	Mod. 9402 Page 12 	Mod. D2003 S01 Page 12 	Mod. D2032 Page 13 	Mod. D2077 Page 13 
Mod. D3043 Page 13 	Mod. D2602 Page 14 	Mod. D2612 Page 14 	Mod. VPC Page 14 	Mod. VDC Page 15 	Mod. V604 Page 15 	Mod. TRN Page 16 	Mod. DRK Page 16 
Mod. PNZ Page 16 	Mod. PNZP Page 16 	TRUCK-DCASE/9000 Page 17 	TRUCK-DCASE/6000 Page 17 	TRUCK-DCASE/9000+6000 Page 17 			

For further information about availability and delivery times, we kindly suggest you to contact our sales network available on www.camozzi.com.

Series 9000 C-Truck Fittings

For polyamide tubes with external diameter:
4, 6, 8, 10, 12, 15, 16 and 18mm



Series 9000 C-Truck fittings have been designed to connect tubes in the pneumatic braking systems on industrial and commercial vehicles, thus ensuring reliability and ease of assembling. The use of a proper disconnection tool enables to disconnect the tube without having to remove the fitting. All fittings have a protective cap that keeps humidity and dirt away from the collet.

A reinforced insert enables to keep the dimensions of the tube constant, thus ensuring a tight and safe connection even in case of high changes in temperature. Indeed, C-Truck fittings can be used at extreme temperatures (from -50°C to +100°C). They are assembled according to a precise angle and supplied with a locking nut and a self sealing O-ring. The O-ring on the thread is set in a special groove of the threaded part, ensuring there is no damage during assembly. The body in brass guarantees a high resistance to corrosion, whilst O-ring and protective cap are made from a rubber

which is resistant to oils. Even though the working pressure depends on the tube used, its maximum value is 16 bar. All fittings are supplied pre-assembled and are therefore ready to use.

GENERAL DATA

Materials	see the table on the next page
Thread	Metric NPTF
Media	Compressed air
Maximum working pressure	16 bar Note: pressure depends on tube characteristics
Temperature	-50°C ÷ +100°C (see tube characteristics)
Tube	Material: Polyamide Tube diameters (D/d): 4/2, 6/4, 8/6, 10/7, 10/8, 12/9, 15/11, 15/12, 16/12, 16/13 and 18/14

Other models are available upon request. For further information we suggest you to contact directly our technical office at Lumezzane plant.

TABLE OF MATERIALS

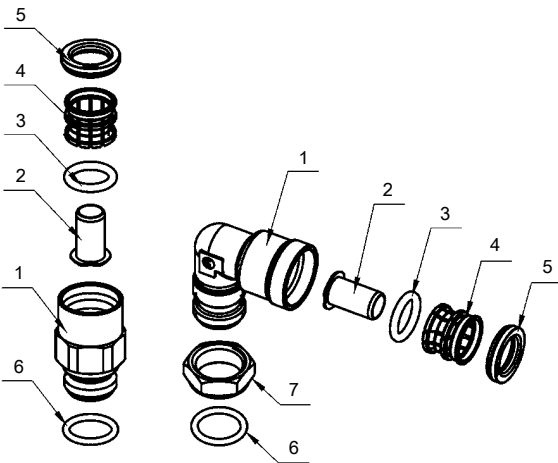

PARTS	MATERIALS
1 = Body	Brass
2 = Insert	Technopolymer (Brass only for Ø10/7, 15/11, 16/12, 16/13 and 18/14)
3 = S-rapid O-Ring	NBR
4 = Collet	Brass
5 = Protective seal	NBR
6 = O-Ring for thread	NBR
7 = Locking ring	Steel

FITTINGS ASSEMBLY IN THE SYSTEM

To guarantee the tightening of the fitting in the system, make sure that the thread chamfer conforms to the standard ISO 965 or GOST 10549-80.

The fittings which have an O-Ring seal on the thread, but no locking nut, have to be screwed into the system with the torque forces as shown in the table below.

For the assembly of fittings with locking nut, it is necessary to do the following:

1. loosen the locking nut
2. screw the fitting into the system until the O-ring comes into contact with the system surface
3. position the fitting according to the suitable angle, moving the body up to 360°
4. keep the body still
5. screw the locking nut with torque forces as shown in the table

Thread	Torque force (Nm)
M10X1	11 - 15
M12X1.5	15 - 19
M14X1.5	19 - 23
M16X1.5	24 - 30
M18X1.5	27 - 33
M22X1.5	36 - 44

ASSEMBLY AND DISASSEMBLY OF THE TUBE INTO THE FITTING

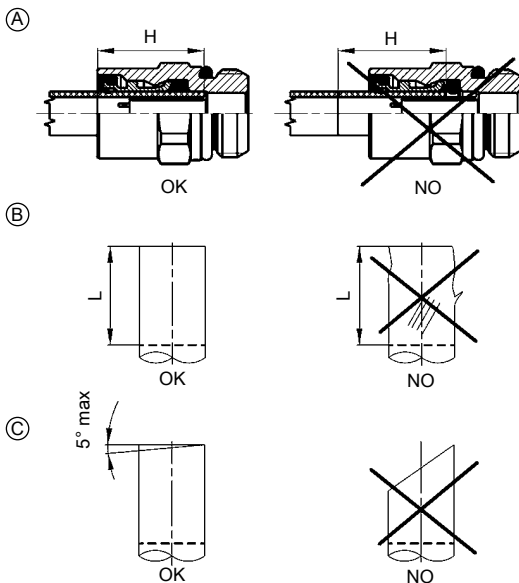

The tube needs to be inserted into the fitting up to the insert stop (A) for the whole length H. It is recommended that you mark the tube to indicate that it has been fully inserted into the fitting.

To guarantee the tube seal with the fitting, it is necessary that the end of the tube that has been inserted for the whole length L is free from any form of damage (B).

To cut the tube end properly, it is recommended that you use the tube cutting tool mod. PNZ.

The angle between the tube and the fitting should not be greater than 5° (C).

Tube Outer/Inner diameter	Assembly length H (mm)	Insert length L (mm)
4/2	18.5	9.5
6/4	17.5	9.5
8/6	19.5	9.5
10/7	21	11
10/8	21	11
12/9	21.5	11
15/11	25	11.5
15/12	25	11.5
16/12	27.5	13
16/13	27.5	13
18/14	27.5	13

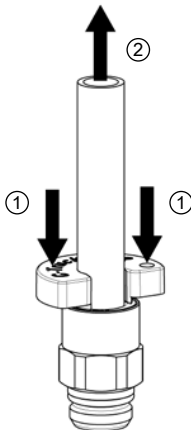

To disconnect the tube it is necessary to push the fittings protective cap using the special disconnection tool (1). First make sure there is no air present inside and then press the protective cap in towards the fittings body (2).

The tube can then be removed from the fitting.

Tube assembly and disassembly must be carried out by a technician who has a detailed knowledge of the fittings construction.

Series 9000 C-Truck Fittings

Straight fittings Mod. 9512

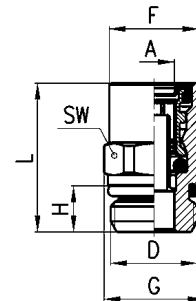

DIMENSIONS

Mod.	A	D	F	G	H	L	SW	Weight (g)	Package (pcs)
9512 6-M10x1	6/4	M10x1	13.8	15	7	27.5	14	18	10
9512 6-M12x1,5	6/4	M12x1,5	13.8	15	8.5	26	14	17	10
9512 6-M14x1,5	6/4	M14x1,5	13.8	15	8.5	25	14	18	10
9512 6-M16x1,5	6/4	M16x1,5	13.8	17	8.5	19.5	14	18	10
9512 8-M10x1	8/6	M10x1	16.5	18.5	7	30	17	27	10
9512 8-M12x1,5	8/6	M12x1,5	16.5	18.5	8.5	30.5	17	27	10
9512 8-M14x1,5	8/6	M14x1,5	16.5	18.5	8.5	27.5	17	25	10
9512 8-M16x1,5	8/6	M16x1,5	16.5	18.5	8.5	27	17	29	10
9512 8-M22x1,5	8/6	M22x1,5	16.5	23.5	8.5	21	19	39	10
9512 10/7-M12x1,5	10/7	M12x1,5	17.8	19.5	8.5	33.5	18	29	10
9512 10/7-M16x1,5	10/7	M16x1,5	17.8	19.5	8.5	28	18	27	10
9512 10/7-M22x1,5	10/7	M22x1,5	18.5	23.5	8.5	22.5	19	36	10
9512 10-M12x1,5	10/8	M12x1,5	17.8	19.5	8.5	33.5	18	29	10
9512 10-M16x1,5	10/8	M16x1,5	17.8	19.5	8.5	28	18	27	10
9512 10-M18x1,5	10/8	M18x1,5	17.8	19.5	8.5	28	18	31	10
9512 10-M22x1,5	10/8	M22x1,5	18.5	23.5	8.5	22.5	19	36	10
9512 12-M12x1,5	12/9	M12x1,5	19.8	21.5	8.5	34	20	32	10
9512 12-M14x1,5	12/9	M14x1,5	19.8	21.5	8.5	33.5	20	35	10
9512 12-M16x1,5	12/9	M16x1,5	19.8	21.5	8.5	32.5	20	36	10
9512 12-M22x1,5	12/9	M22x1,5	20.5	24	8.5	23	22	37	10
9512 15/11-M16x1,5	15/11	M16x1,5	23.8	26.5	8.5	37.5	24	52	10
9512 15/11-M22x1,5	15/11	M22x1,5	23.8	26.5	8.5	30.5	24	49	10
9512 15-M16x1,5	15/12	M16x1,5	23.8	26.5	8.5	37.5	24	52	10
9512 15-M22x1,5	15/12	M22x1,5	23.8	26.5	8.5	30.5	24	49	10
9512 16/12-M16x1,5	16/12	M16x1,5	25	30	8.5	41	27	71	10
9512 16/12-M22x1,5	16/12	M22x1,5	25	30	8.5	33.5	27	67	10
9512 16-M22x1,5	16/13	M22x1,5	25	30	8.5	33.5	27	67	10
9512 18-M22x1,5	18/14	M22x1,5	26.8	30	8.5	38.5	27	71	10

Straight fittings Mod. D6512



Supplied without any insert

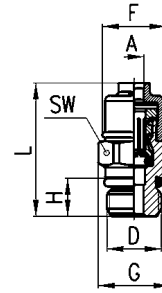

DIMENSIONS

Mod.	A	D	F	G	H	L	SW	Weight (g)	Package (pcs)
D6512 4-M10x1	4	M10x1	11.7	13.2	7	24.5	12	10	10

Straight fittings Mod. 9510

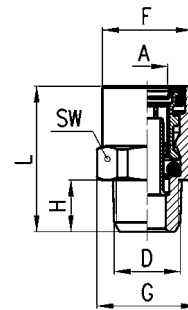

DIMENSIONS

Mod.	A	D	F	G	H	L	SW	Weight (g)	Package (pcs)
9510 6-02	6/4	1/8 NPTF	13.8	15	8	24.5	14	15	10
9510 05-02	8/6	1/8 NPTF	16.5	18.5	8	30	17	25	10

Fittings with female thread Mod. 9463

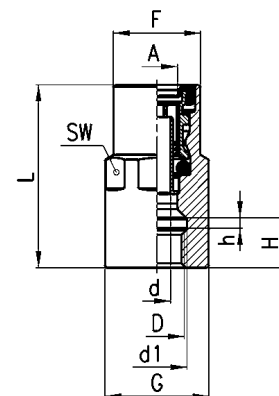

DIMENSIONS

Mod.	A	D	d	d1	H	h	L	F	G	SW	Weight (g)	Pack. (pcs)
9463 6-M10x1	6/4	M10x1	3	11	9	2	31.5	13.8	15	14	26	10
9463 6-M16x1,5	6/4	M16x1,5	3	-	10.5	-	34	15.3	21	19	49	10
9463 8-M10x1	8/6	M10x1	5	11	9	2	33	16.5	18.5	17	45	10

Elbow fittings Mod. 9502

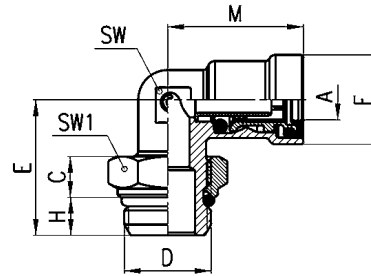

DIMENSIONS

Mod.	A	C	D	E	F	H	M	SW	SW1	Weight (g)	Package (pcs)
9502 6-M10x1	6/4	5	M10x1	21	14.5	5	22.5	9	14	24	10
9502 6-M12x1,5	6/4	7	M12x1,5	23.5	14.5	7.5	22.5	9	17	28	10
9502 6-M16x1,5	6/4	7.5	M16x1,5	25	14.5	7	23	11	19	37	10
9502 8-M10x1	8/6	5	M10x1	22	16.5	5	25	11	14	29	10
9502 8-M12x1,5	8/6	7	M12x1,5	25	16.5	7.5	25	11	17	35	10
9502 8-M14x1,5	8/6	7	M14x1,5	25	16.5	7.5	25	11	19	37	10
9502 8-M16x1,5	8/6	7.5	M16x1,5	25	16.5	7	25	11	19	36	10
9502 8-M22x1,5	8/6	8.5	M22x1,5	29	16.5	8	25	11	27	58	10
9502 10/7-M12x1,5	10/7	7	M12x1,5	26	18.5	7.5	27	13	17	43	10
9502 10/7-M16x1,5	10/7	7.5	M16x1,5	26	18.5	7	27	13	19	45	10
9502 10/7-M22x1,5	10/7	8.5	M22x1,5	29	18.5	8	27	13	27	66	10
9502 10-M12x1,5	10/8	7	M12x1,5	26	18.5	7.5	27	13	17	43	10
9502 10-M16x1,5	10/8	7.5	M16x1,5	26	18.5	7	27	13	19	45	10
9502 10-M22x1,5	10/8	8.5	M22x1,5	29	18.5	8	27	13	27	66	10
9502 12-M12x1,5	12/9	7	M12x1,5	27	20.5	7.5	28.5	15	17	51	10
9502 12-M16x1,5	12/9	7.5	M16x1,5	27	20.5	7	28.5	15	19	50	10
9502 12-M22x1,5	12/9	8.5	M22x1,5	30	20.5	8	28.5	15	27	71	10
9502 15/11-M16x1,5	15/11	7.5	M16x1,5	30.5	24.5	7	34	18	19	81	10
9502 15/11-M22x1,5	15/11	8.5	M22x1,5	34	24.5	8	34	18	27	99	10
9502 15-M16x1,5	15/12	7.5	M16x1,5	30.5	24.5	7	34	18	19	81	10
9502 15-M22x1,5	15/12	8.5	M22x1,5	34	24.5	8	34	18	27	99	10
9502 16/12-M16x1,5	16/12	7.5	M16x1,5	32	25	7	35.5	21	19	108	10
9502 16/12-M22x1,5	16/12	8.5	M22x1,5	33	25	8	35.5	21	27	119	10
9502 16-M22x1,5	16/13	8.5	M22x1,5	33	25	8	35.5	21	27	119	10
9502 18-M22x1,5	18/14	8.5	M22x1,5	33	27.5	8	35.5	21	27	123	10

Elbow fittings Mod. 9500

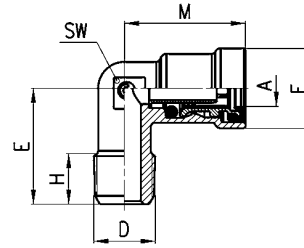

DIMENSIONS									
Mod.	A	D	E	F	H (min)	M	SW	Weight (g)	Package (pcs)
9500 6-02	6/4	1/8 NPTF	17.5	14.5	7	21.5	9	17	10
9500 05-02	8/6	1/8 NPTF	17	16.5	7	25	11	23	10
9500 12-06	12/9	3/8 NPTF	24.5	20.5	11	28.5	15	43	10

Tee fittings Mod. 9412

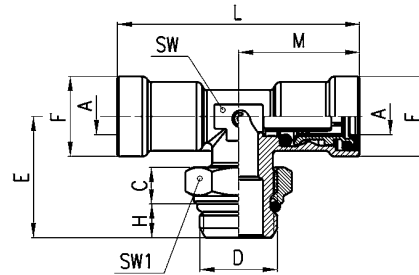

DIMENSIONS												
Mod.	A	C	D	E	F	H	L	M	SW	SW1	Weight (g)	Pack. (pcs)
9412 6-M10x1	6/4	5	M10x1	22	14.5	5	45	22.5	9	14	35	10
9412 6-M12x1,5	6/4	7	M12x1.5	27	14.5	7.5	46	23	11	17	52	10
9412 6-M16x1,5	6/4	7.5	M16x1.5	27	14.5	7	46	23	11	19	55	10
9412 8-M12x1,5	8/6	7	M12x1.5	27	16.5	7.5	50	25	11	17	53	10
9412 8-M16x1,5	8/6	7.5	M16x1.5	27	16.5	7	50	25	11	19	57	10
9412 8-M22x1,5	8/6	8.5	M22x1.5	32	16.5	8	53	26.5	15	27	94	10
9412 10/7-M12x1,5	10/7	7	M12x1.5	29	18.5	7.5	55	27.5	15	17	79	10
9412 10/7-M16x1,5	10/7	7.5	M16x1.5	29	18.5	7	55	27.5	15	19	81	10
9412 10/7-M22x1,5	10/7	8.5	M22x1.5	32	18.5	8	55	27.5	15	27	101	10
9412 10-M12x1,5	10/8	7	M12x1.5	29	18.5	7.5	55	27.5	15	17	79	10
9412 10-M16x1,5	10/8	7.5	M16x1.5	29	18.5	7	55	27.5	15	19	81	10
9412 10-M22x1,5	10/8	8.5	M22x1.5	32	18.5	8	55	27.5	15	27	101	10
9412 12-M12x1,5	12/9	7	M12x1.5	29	20.5	7.5	57	28.5	15	17	72	10
9412 12-M16x1,5	12/9	7.5	M16x1.5	29	20.5	7	57	28.5	15	19	74	10
9412 12-M22x1,5	12/9	8.5	M22x1.5	32	20.5	8	57	28.5	15	27	93	10
9412 15/11-M16x1,5	15/11	7.5	M16x1.5	32.5	24.5	7	68	34	18	19	115	10
9412 15/11-M22x1,5	15/11	8.5	M22x1.5	34	24.5	8	68	34	18	27	134	10
9412 15-M16x1,5	15/12	7.5	M16x1.5	32.5	24.5	7	68	34	18	19	115	10
9412 15-M22x1,5	15/12	8.5	M22x1.5	34	24.5	8	68	34	18	27	134	10

Tee fittings Mod. 9410

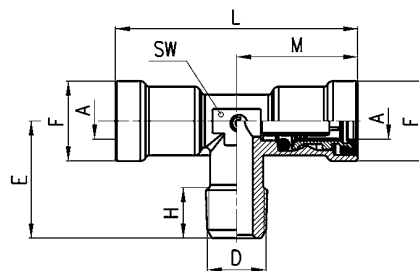

DIMENSIONS										
Mod.	A	D	E	F	H (min)	L	M	SW	Weight (g)	Package (pcs)
9410 6-02	6/4	1/8 NPTF	17.5	14.5	7	45	22.5	9	29	10
9410 05-02	8/6	1/8 NPTF	18	16.5	7	50	25	11	39	10

Tee fittings Mod. 9422

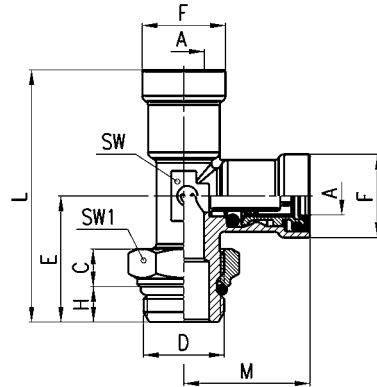

DIMENSIONS												
Mod.	A	C	D	E	F	H	L	M	SW	SW1	Weight (g)	Pack. (pcs)
9422 6-M10x1	6/4	5	M10x1	22	14.5	5	44.5	22.5	9	14	35	10
9422 6-M12x1,5	6/4	7	M12x1,5	27	14.5	7.5	50	23	11	17	52	10
9422 6-M16x1,5	6/4	7.5	M16x1,5	27	14.5	7	50	23	11	19	54	10
9422 8-M12x1,5	8/6	7	M12x1,5	27	16.5	7.5	52	25	11	17	54	10
9422 8-M16x1,5	8/6	7.5	M16x1,5	27	16.5	7	52	25	11	19	57	10
9422 8-M22x1,5	8/6	8.5	M22x1,5	32	16.5	8	58.5	26.5	15	27	95	10
9422 10-M16x1,5	10/8	7.5	M16x1,5	29	18.5	7	56.5	27.5	15	19	81	10
9422 10-M22x1,5	10/8	8.5	M22x1,5	32	18.5	8	59.5	27.5	15	27	102	10
9422 12-M12x1,5	12/9	7	M12x1,5	29	20.5	7.5	57.5	28.5	15	17	73	10
9422 12-M16x1,5	12/9	7.5	M16x1,5	29	20.5	7	57.5	28.5	15	19	72	10
9422 12-M22x1,5	12/9	8.5	M22x1,5	32	20.5	8	60.5	28.5	15	27	95	10
9422 15-M16x1,5	15/12	7.5	M16x1,5	32.5	24.5	7	66.5	34	18	19	117	10
9422 15-M22x1,5	15/12	8.5	M22x1,5	34	24.5	8	68	34	18	27	134	10

Tee fittings Mod. 9420

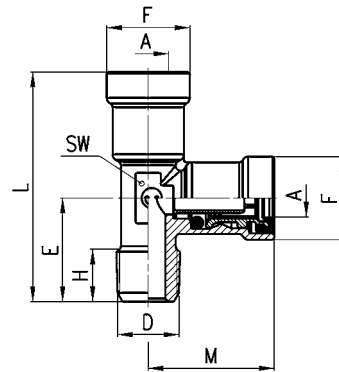

DIMENSIONS											
Mod.	A	D	E	F	H (min)	L	M	SW	Weight (g)	Package (pcs)	
9420 6-02	6/4	1/8 NPTF	17.5	14.5	7	40	22.5	9	29	10	
9420 05-02	8/6	1/8 NPTF	18	16.5	7	43	25	11	40	10	

Connectors Mod. 9580

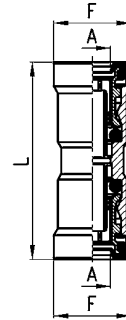

DIMENSIONS					
Mod.	A	F	L	Weight (g)	Package (pcs)
9580 6	6/4	14	37.5	20	10
9580 8	8/6	16	41	27	10
9580 10	10/8	18	44	32	10
9580 10/7	10/7	18	44	32	10
9580 12	12/9	20	45.5	43	10
9580 15/11	15/11	24	52	87	10
9580 16/12	16/12	25	58	100	10
9580 18	18/14	27	57	109	10

Bulkhead connectors Mod. 9590

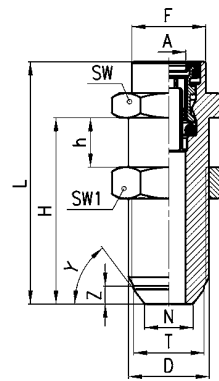

DIMENSIONS														
Mod.	A	D	F	H	h	L	N	T	Y	Z	SW	SW1	Weight (g)	Package (pcs)
9590 8-M18x1,5	8/6	M18x1.5	-	50	10	55.5	10.8	15.7	53	4	22	22	88	10
9590 12-M18x1,5	12/9	M18x1.5	20.5	34	4	53	11	16	60	5	22	22	83	10
9590 12-M18x1,5-S04	12/9	M18x1.5	20.5	33	4	52	10.8	15.7	53	4	22	-	71	10

Bulkhead connectors Mod. 9592

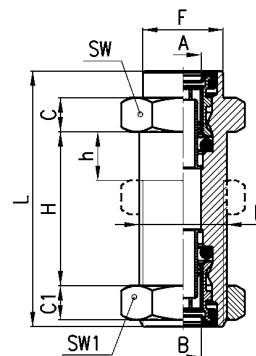

DIMENSIONS													
Mod.	A	B	C	C1	D	F	H	h (min)	L	SW	SW1	Weight (g)	Package (pcs)
9592 8-8-M18X1	8/6	8/6	5.5	7	M18x1	-	30	18	43.5	22	22	75	10
9592 12-8-M18X1	12/9	8/6	7.5	7	M18x1	20.5	30	18	57	22	22	87	10

Tee fittings Mod. 9540

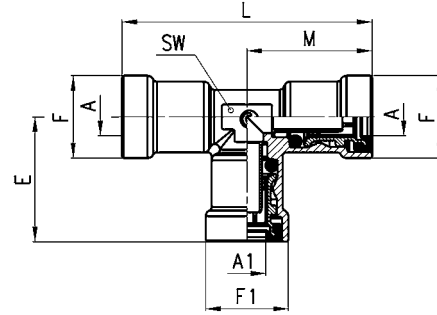

DIMENSIONS										
Mod.	A	A1	E	F	F1	L	M	SW	Weight (g)	Pack. (pcs)
9540 6	6/4	6/4	22.5	14.5	14.5	45	22.5	9	35	10
9540 8	8/6	8/6	25	16.5	16.5	50	25	11	52	10
9540 10	10/8	10/8	27.5	18.5	18.5	55	27.5	15	80	10
9540 10/7	10/7	10/7	27.5	18.5	18.5	55	27.5	15	80	10
9540 12	12/9	12/9	28.5	20.5	20.5	57	28.5	15	73	10
9540 15/11	15/11	15/11	34	24.5	24.5	68	34	18	134	10
9540 8-8-6	8/6	6/4	23	16.5	14.5	50	25	11	49	10
9540 12-12-8	12/9	8/6	26.5	20.5	16.5	57	28.5	15	72	10

Bulkhead connectors Mod. D2512 and D2502

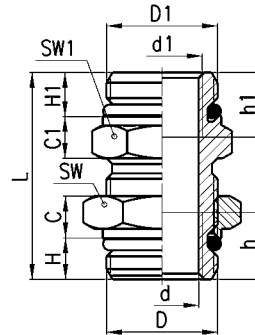

DIMENSIONS																
Mod.	D	D1	d	d1	H	H1	h (min)	h1 (min)	C	C1	L	SW	SW1	Weight (g)	Package (pcs)	
D2512 M22x1,5-M16x1,5	M22x1.5	M16x1.5	M16x1.5	M10x1	8	8.5	10.5	10.5	8.5	8.5	48	27	22	78	10	
D2502 M22x1,5-M22x1,5	M22x1.5	M22x1.5	-	-	8	8.5	-	-	8.5	8.5	39	27	24	77	10	

Elbow fittings Mod. D2022

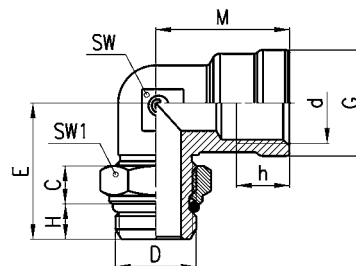

DIMENSIONS													
Mod.	D	d	C	E	G	H	h (min)	M	SW	SW1	Weight (g)	Package (pcs)	
D2022 M16x1,5-M16x1,5	M16x1.5	M16x1.5	7.5	27	21	7	10.5	26.5	15	19	51	10	
D2022 M16x1,5-M22x1,5	M22x1.5	M16x1.5	8.5	30	21	8	10.5	26.5	15	27	70	10	
D2022 M22x1,5-M22x1,5	M22x1.5	M22x1.5	8.5	33	27	8	11	22	24	27	91	10	

Tee fittings Mod. D2062

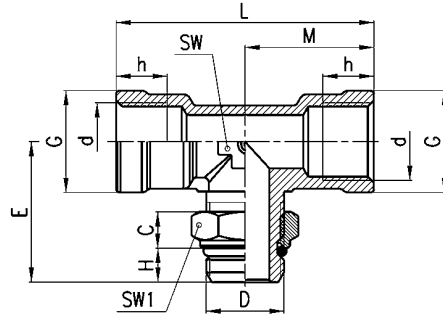

DIMENSIONS

Mod.	d	D	C	E	G	H	h (min)	L	M	SW	SW1	Weight (g)	Package (pcs)
D2062 M16x1,5-M12x1,5	M16x1.5	M22x1.5	7	29	21	7.5	10.5	53	26.5	15	17	76	10
D2062 M16x1,5-M16x1,5	M16x1.5	M16x1.5	7.5	29	21	7	10.5	37	18.5	20	19	64	10
D2062 M16x1,5-M22x1,5	M16x1.5	M22x1.5	8.5	32	21	8	10.5	37	18.5	20	27	86	10
D2062 M22x1,5-M22x1,5	M22x1.5	M22x1.5	8.5	33	27	8	11	64	32	20	27	127	10

Tee fittings Mod. D2072

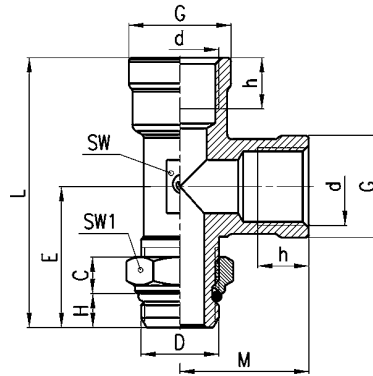

DIMENSIONS

Mod.	d	D	C	E	G	H	h (min)	L	M	SW	SW1	Weight (g)	Package (pcs)
D2072 M16x1,5-M12x1,5	M16x1.5	M22x1.5	7	29	21	7.5	10.5	55.5	26.5	15	17	67	10
D2072 M16x1,5-M16x1,5	M16x1.5	M16x1.5	7.5	29	21	7	10.5	47.5	18.5	20	19	64	10
D2072 M16x1,5-M22x1,5	M16x1.5	M22x1.5	8.5	32	21	8	10.5	50.5	18.5	20	27	86	10
D2072 M22x1,5-M22x1,5	M22x1.5	M22x1.5	8.5	33	27	8	11	65	32	20	27	127	10

Tee fittings Mod. D2003

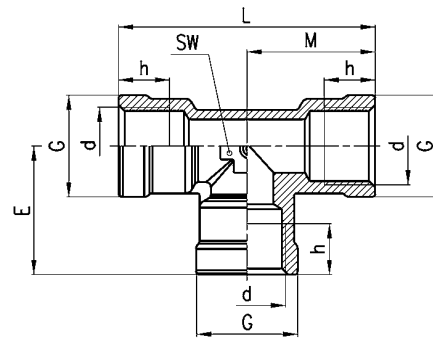

DIMENSIONS

Mod.	d	E	G	h (min)	M	L	SW	Weight (g)	Package (pcs)
D2003 M16x1,5	M16x1.5	18.5	21	10.5	18.5	37	20	49	10
D2003 M22x1,5	M22x1.5	32	27	11	32	64	20	117	10

Y fittings Mod. 9450

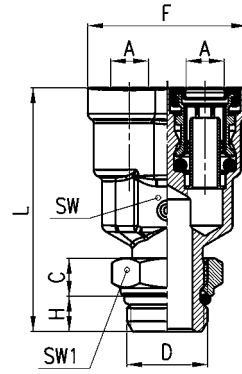

DIMENSIONS

Mod.	A	C	D	F	H	L	SW	SW1	Weight (g)	Package (pcs)
9450 8-M16x1,5	8/6	7.5	M16x1.5	31.5	7	48.3	14	19	62	10
9450 12-M16x1,5	12/9	7.5	M16x1.5	40	7	58.7	20	19	120	10
9450 12-M22x1,5	12/9	8.5	M22x1.5	40	8	59.2	20	27	131	10

Elbow fittings Mod. 9402

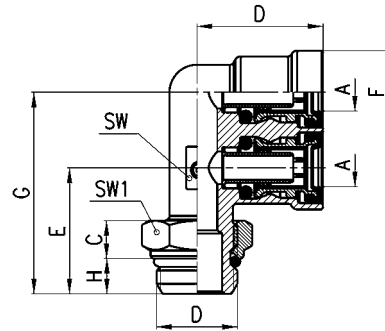

DIMENSIONS

Mod.	A	C	D	E	F	G	H	SW	Weight (g)	Pack. (pcs)
9402 12-M16x1,5	12/9	7.5	M16x1.5	31	Ø21	50	7	15	98	10
9402 12-M22x1,5	12/9	8.5	M22x1.5	30	Ø21	49	8	15	111	10

Tee fittings Mod. D2003...S01

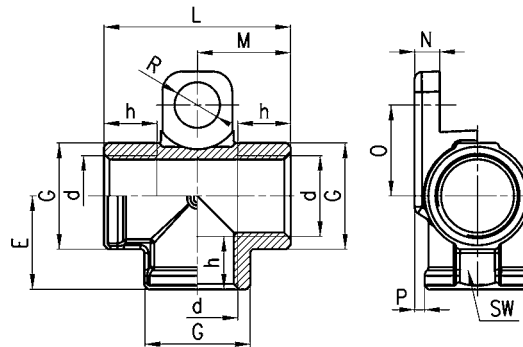

DIMENSIONS

Mod.	d	E	G	h (min)	L	M	N	O	P	R	SW	Weight (g)	Package (pcs)
D2003 M16x1,5-S01	M16x1.5	18.5	21	10.5	37	18.5	5	18	2	9	21	49	10

Cross fittings Mod. D2032

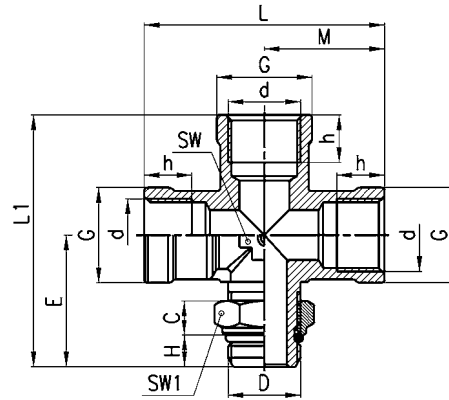

DIMENSIONS

Mod.	d	D	C	E	G	H	h	L	L1	M	SW	SW1	Weight (g)	Package (pcs)
D2032 M16x1,5-M16x1,5	M16x1.5	M16x1.5	7	29	21	7.5	10.5	56	57	28	15	17	110	10

Elbow fittings Mod. D2077

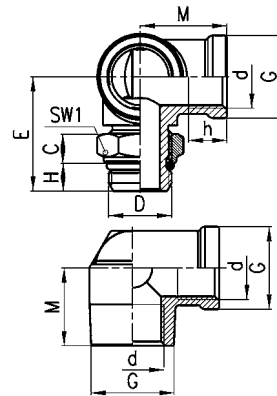

DIMENSIONS

Mod.	D	d	C	E	G	H	h	M	SW	Weight (g)	Package (pcs)
D2077 M16x1,5-M16x1,5-S01	M16x1.5	M16x1.5	7.5	34	21	7	10.5	22	19	85	10
D2077 M16x1,5-M22x1,5-S01	M16x1.5	M22x1.5	8.5	35.5	21	8	10.5	22	27	95	10

Fittings Mod. D3043

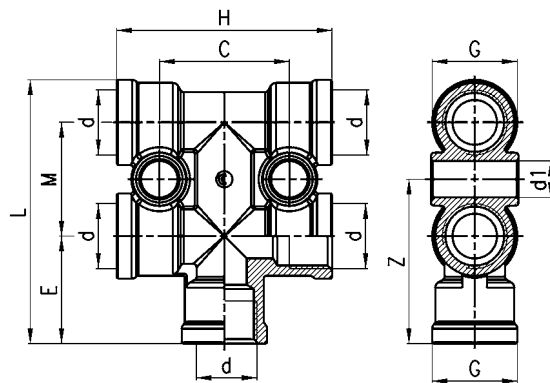

DIMENSIONS

Mod.	d	d1	C	E	M	L	H	G	Z	Weight (g)	Package (pcs)
D3043 M16X1,5-2D-M16X1,5-S01	M16X1.5	9	32	26.5	28	65	53	21	40.5	135	10

Hose adapters Mod. D2602

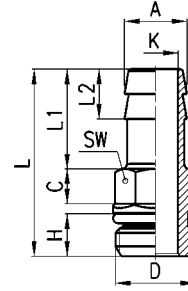

DIMENSIONS

Mod.	A	D	H	C	L	L1	L2	K	SW	Weight (g)	Pack. (pcs)
D2602 10-M16X1,5-L=30	11	M16x1.5	8.5	5	46	30	10	7.5	14	26	10
D2602 11,5-M16X1,5-L=35	12.5	M16x1.5	8.5	5	51	35	10	9	14	26	10
D2602 12-M16x1,5	12.5	M16x1.5	8.5	5	36	20	10	9	14	22	10
D2602 12-M22x1,5	12.5	M22x1.5	8.5	5	36.5	20	10	9	19	34	10
D2602 13-M16x1,5-S01	15	M16x1.5	9	7	56	40	10	10	22	48	10

Taps Mod. D2612

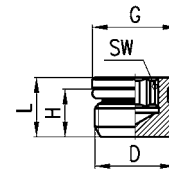

DIMENSIONS

Mod.	D	H	L	G	SW	Weight (g)	Package (pcs)
D2612 M12x1,5	M12x1.5	8.5	10.5	12.9	6	6	10
D2612 M16x1,5	M16x1.5	8.5	11	17	8	12	10
D2612 M22x1,5	M22x1.5	8.5	11.5	23.5	12	24	10

Test point valve Mod. VPC

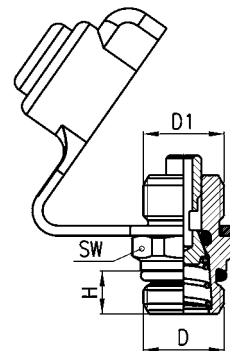

DIMENSIONS

Mod.	D	D1	H	L	SW	Weight (g)	Package (pcs)
VPC M16x1,5-M16x1,5	M16x1.5	M16x1.5	8.5	27.5	19	40	10
VPC M22x1,5-M16x1,5	M22x1.5	M16x1.5	8.5	27	24	51	10

Drain valve Mod. VDC

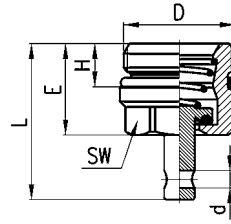

DIMENSIONS

Mod.	D	d	H	E	L	SW	Weight (g)	Package (pcs)
VDC M22X1,5	M22x1.5	3.4	8.5	18	30.7	19	32	10

Fittings Mod. V604



A = rod position for tire inflation
 B = rod position for tank filling
 through air intake for tire inflation

2 = energy supply
 3 = drain
 11, 12 = energy flow

Flow 2 + 11 bar at 6 bar ΔP 1: 1620 l/min
 Flow 2 + 12 bar at 6 bar with no interruption:
 400 l/min
 Safety pressure: 10 bar Q = 100 l/min;
 8 bar Q = 0 l/min

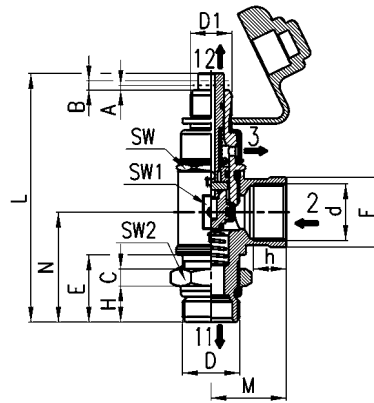

DIMENSIONS

Mod.	C	D	D1	d	E	F	H	h (min)	L	M	N	SW	SW1	SW2	Weight (g)	Package (pcs)
V604 M22X1,5-S01	8.5	M22X1.5	M16X1.5	M22X1.5	26	27	12	11	95	29	42.5	24	27	27	250	2

Tubes Mod. TRN



Black tubes in polyamide (PA12)

According to standards:

- DIN 74324
- REACH REGULATION (EC N°1907/2006)
- EUROPEAN DIRECTIVE RoHS n° 2002/95/EC

CHARACTERISTICS

Mod.	D/d	MAX pressure at 23°C (bar)	Weight (g/m)	Min. curve radius (mm)	Operating temperature (°C)	Size (m)
TRN 4/2 NX	4/2	49	9.6	16	-55°C + +100°C	50
TRN 6/4 NX	6/4	29	16	30	-55°C + +100°C	50
TRN 8/6 NX	8/6	21	22.4	40	-55°C + +100°C	50
TRN 10/8 NX	10/8	16	28.8	60	-55°C + +100°C	50
TRN 12/9 NX	12/9	21	50.4	60	-55°C + +100°C	50
TRN 15/12 NX	15/12	16	64.9	90	-55°C + +100°C	50
TRN 16/13 NX	16/13	13	71	120	-55°C + +100°C	50
TRN 18/14 NX	18/14	18	102.5	100	-55°C + +100°C	50

* TRN 16/13 NX not foreseen by DIN 74324 standard

Tube cutter tool Mod. PNZ and PNZP



PNZ-25

PNZP-12

Mod.

PNZ-12	able to cut tubes with Ø up to 12 mm
PNZ-25	able to cut tubes with Ø up to 25 mm
PNZP-12	able to cut tubes with Ø up to 12 mm

Tube disconnecting key Mod. DRK

Material: technopolymer

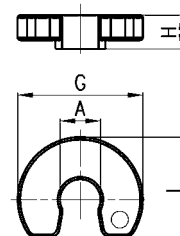

DIMENSIONS

Mod.	A	G	H	L	Weight (g)	Package (pcs)
DRK 6	6	25	6	19	1	10
DRK 8	8	28.5	7	20	1	10
DRK 10	10	30.5	9	22	2	10
DRK 12	12	33	9	23	3	10
DRK 15	15	36	10	27	3	10
DRK 16	16	37	10	27.5	4	10
DRK 18	18	40	12	31	5	10

Repair kit with Series 9000 C-Truck fittings

For braking systems of industrial vehicles

The kit is supplied with:

2x 9580 6	1x DRK 6	1x PNZP-12
2x 9580 8	1x DRK 8	
2x 9580 10	1x DRK 10	
2x 9580 12	1x DRK 12	



Mod.

TRUCK-DCASE/9000

Repair kit with Series 6000 fittings

For accessory equipment of industrial vehicles

The kit is supplied with:

2x 6580 4	2x 6580 10	1x PNZP-12
2x 6580 5	1x 6580 12	
2x 6580 6	1x 6580 14	
2x 6580 8		



Mod.

TRUCK-DCASE/6000

Repair kit with Series 9000 C-Truck and Series 6000 fittings

For braking systems (Series 9000) and accessory equipment of industrial vehicles (Series 6000)

The kit is supplied with:

1x 6580 4	2x 6580 10	2x 9580 6	1x DRK 6
1x 6580 5	1x 6580 12	2x 9580 8	1x DRK 8
1x 6580 6	1x 6580 14	1x 9580 10	1x DRK 10
1x 6580 8		1x 9580 12	1x DRK 12
			1x PNZP-12



Mod.

TRUCK-DCASE/9000+6000