

IE2 Electric Motors



WE Series, Cast Iron, 3 Phase

WE series three phase asynchronous motor is complete new designed high efficiency motor with cast iron housing. Its efficiency indicators are in line with IE2 and Australia MEPS2 (Level 1A).

Characteristics for all WONDER standard 3-Phase asynchronous motors

- Widely applied in general machinery and industries such as pumps & water treatment, road machinery, petroleum, chemical, metallurgy, cement and paper-milling.
- IP55 protection, Class F Insulation, B Temperature rise, S1 duty.
- Rated voltage 400V, Rated frequency 50Hz.
- Operation conditions: ambient temperature: -20°C ~ 40°C, altitude ≤ 1000m.
- Y-connection for motors up to 3kW and Δ-connection for 4kW and above
- Cooling method is Ic411.



MOUNTING ARRANGEMENTS

Types	Basic type of construction	Derived types of construction				
WE80-355	IM B3 IM 10 01	IM V5 IM 10 11	IM V6 IM 10 21	IM B6 IM 10 51	IM B7 IM 10 61	IM B8 IM 10 71
WE80-355	IM B35 IM 2001	IM V15 IM 20 11	IM V36 IM 20 31	IM 20 51	IM 20 61	IM 20 71
W80-160	IM B34 IM 2101	IM 21 11	IM 21 31	IM 21 51	IM 21 61	IM 21 71
WE80-355	IM B5 IM 3001	IM V1 IM 30 11	IM V6 IM 30 31			
W80-160	IM B14 IM 3601	IM V18 IM 36 11	IM V19 IM 36 31			

basic types of construction may be used in all derived types of construction
 (*)not-defined mounting by IEC 60034-7
 1) for the types of construction IM V3, IM B6, IM B8 inquiry is necessary.

WE SERIES PERFORMANCE DATA

TECHNICAL SPECIFICATIONS



Output		IEC Frame	Rated speed (rpm)	Full load current I_n (A)		Efficiency η%			Power factor cosφ			Locked rotor current I_L/I_n	Locked rotor torque T_L/T_n	Break-down torque T_b/T_n	Sound LP dB(A)	Moment of inertia J(kg·m ²)	Weight (kg)
kW	HP			400V	525V	100	75	50	100	75	50						
3000 min-1(2poles) 50Hz																	
0.18	0.25	63	2750	0.51	0.39	71.0	68.5	64.5	0.72	0.67	0.58	5.0	2.8	3.0	52	0.0005	7.6
0.25	0.33	63	2750	0.69	0.52	72.0	67.5	64.0	0.73	0.68	0.60	5.2	3.0	3.2	52	0.0007	8.2
0.37	0.5	71	2820	0.88	0.67	75.0	73.5	69.0	0.81	0.75	0.63	5.5	3.1	3.2	56	0.0008	12
0.55	0.75	71	2820	1.26	0.96	76.0	75.3	72.5	0.83	0.78	0.65	6.0	3.3	3.5	56	0.0009	13
0.75	1	80	2875	1.78	1.35	78.1	78.0	76.7	0.78	0.89	0.57	6.5	3.6	4.0	60	0.0011	17
1.1	1.5	80	2875	2.48	1.89	81.0	80.8	79.3	0.79	0.72	0.68	6.6	3.7	3.9	60	0.0013	18
1.5	2	90S	2900	3.00	2.28	82.1	81.8	81.0	0.88	0.83	0.75	6.6	2.1	2.9	60	0.0018	23
2.2	3	90L	2900	4.24	3.23	84.2	84.7	83.4	0.89	0.86	0.79	7.0	2.3	2.9	59	0.0022	26
3	4	100L	2900	5.63	4.29	85.4	86.0	85.0	0.90	0.84	0.75	8.0	2.5	4.0	63	0.0042	34
4	5.5	112M	2920	7.52	5.73	86.3	87.0	86.0	0.89	0.85	0.78	6.9	2.2	3.0	63	0.0065	41
5.5	7.5	132S	2925	10.2	7.77	87.5	87.6	86.0	0.89	0.85	0.77	8.2	2.2	3.5	66	0.0145	60
7.5	10	132S	2925	13.8	10.5	88.4	88.8	87.6	0.89	0.87	0.81	8.3	2.3	3.4	66	0.0156	63
11	15	160M	2935	19.6	15.0	89.9	89.7	88.1	0.90	0.89	0.84	7.5	2.2	2.5	68	0.0549	109
15	20	160M	2935	26.5	20.2	90.7	90.7	89.5	0.90	0.88	0.83	7.5	2.2	2.5	68	0.0635	119
18.5	25	160L	2940	32.2	24.5	91.2	91.2	90.1	0.91	0.89	0.84	7.5	2.2	2.2	68	0.0725	136
22	30	180M	2950	38.1	29.1	91.5	91.2	89.6	0.91	0.89	0.83	7.5	2.0	2.2	70	0.1025	172
30	40	200L	2950	51.6	39.3	92.2	91.7	90.4	0.91	0.90	0.86	7.5	2.0	2.3	73	0.173	223
37	50	200L	2950	63.4	48.3	92.6	92.6	91.5	0.91	0.90	0.87	7.5	2.0	2.3	73	0.195	242
45	60	225M	2965	76.7	58.4	93.1	92.7	91.2	0.91	0.90	0.86	7.5	2.0	2.3	75	0.325	302
55	75	250S/M	2970	94.4	72.0	93.4	93.0	91.4	0.90	0.89	0.84	7.5	2.0	2.3	78	0.395	382
75	100	280S	2975	127	96.4	94.0	93.5	92.0	0.91	0.90	0.86	7.5	2.0	2.3	79	0.683	515
90	125	280M	2980	151	115	94.5	94.1	92.7	0.91	0.90	0.86	7.5	2.0	2.3	79	0.765	545
110	150	315S	2975	184	141	94.6	93.9	92.3	0.91	0.89	0.83	7.1	1.8	2.2	80	1.558	930
132	175	315M	2975	221	168	94.8	94.2	92.7	0.91	0.89	0.84	7.1	1.8	2.2	80	1.726	980
160	215	315M/L	2980	267	204	95.0	94.5	93.0	0.91	0.89	0.84	7.1	1.8	2.2	82	1.941	1090
200	270	315M/L	2980	333	254	95.2	94.8	93.6	0.91	0.90	0.85	7.1	1.8	2.2	82	2.212	1190
250	335	355M/L	2985	420	320	95.4	94.8	93.3	0.90	0.89	0.88	7.1	1.6	2.2	83	3.848	1710
280	375	355M/L	2985	470	358	95.6	95.0	93.6	0.90	0.89	0.88	7.1	1.6	2.2	83	3.949	1870
315	420	355M/L	2985	521	397	95.9	95.3	93.9	0.91	0.91	0.89	7.1	1.6	2.2	83	3.995	1920

IE2 efficiency class according to IEC60034-30:2008

Efficiency outside of IEC IE2 standard power range is according to Wonder specification.

Efficiency testing method is according to IEC 60034-2-1:2007

WE SERIES PERFORMANCE DATA

TECHNICAL SPECIFICATIONS

IE2

Output		IEC Frame	Rated speed	Full load current I_n (A)		Efficiency η %			Power factor $\cos\phi$			Locked rotor current I_L/I_n	Locked rotor torque T_L/T_n	Break-down torque T_b/T_n	Sound LP dB(A)	Moment of inertia J (kgm ²)	Weight (kg)
kW	HP		(rpm)	400V	525V	100	75	50	100	75	50						
1500 min ⁻¹ (4 poles) 50Hz																	
0.12	0.16	63	1400	0.40	0.31	65.0	62.3	55.0	0.66	0.53	0.42	3.5	2.5	2.8	44	0.0008	8.2
0.18	0.25	63	1400	0.58	0.44	68.0	64.5	58.0	0.66	0.55	0.44	4.0	2.5	2.8	44	0.0009	8.6
0.25	0.33	71	1400	0.70	0.53	75.0	73.2	69.0	0.69	0.61	0.50	4.4	2.4	3.1	45	0.001	13
0.37	0.5	71	1410	1.03	0.78	75.5	74.1	69.2	0.69	0.59	0.47	4.9	3.1	3.3	45	0.0011	14
0.55	0.75	80	1425	1.41	1.08	77.0	76.5	73.3	0.73	0.66	0.52	5.5	2.2	2.4	46	0.00148	18
0.75	1	80	1425	1.81	1.38	79.6	78.6	77.4	0.75	0.69	0.56	5.4	2.5	2.7	47	0.0016	19
1.1	1.5	90S	1445	2.53	1.93	81.4	81.3	80.2	0.77	0.71	0.59	5.4	2.2	2.6	49	0.00232	23
1.5	2	90L	1445	3.31	2.52	82.8	82.4	81.9	0.79	0.77	0.66	5.4	2.2	2.5	51	0.00315	29
2.2	3	100L	1435	4.65	3.54	84.3	84.4	83.2	0.81	0.75	0.64	6.8	3.0	3.2	51	0.0079	35
3	4	100L	1435	6.25	4.76	85.5	85.5	85.0	0.81	0.75	0.65	6.5	2.9	2.9	51	0.00865	39
4	5.5	112M	1455	8.19	6.24	87.0	86.8	85.8	0.81	0.75	0.70	7.1	2.7	2.8	55	0.0185	45
5.5	7.5	132S	1460	11.0	8.40	87.8	87.6	87.2	0.82	0.77	0.68	7.3	2.4	2.9	55	0.0331	62
7.5	10	132M	1460	14.7	11.2	89.0	88.7	88.1	0.83	0.79	0.70	7.5	2.6	2.8	55	0.0412	74
11	15	160M	1460	20.7	15.8	90.3	90.7	90.2	0.85	0.82	0.76	7.0	2.2	2.5	60	0.1052	115
15	20	160L	1460	27.7	21.1	91.0	91.4	90.8	0.86	0.83	0.77	7.5	2.2	2.5	60	0.1123	135
18.5	25	180M	1470	34.0	25.9	91.3	91.3	90.6	0.86	0.83	0.76	7.5	2.2	2.5	65	0.1659	170
22	30	180L	1470	40.2	30.6	91.8	91.8	90.9	0.86	0.83	0.76	7.5	2.2	2.5	65	0.1865	184
30	40	200L	1470	52.6	40.1	92.5	92.5	91.8	0.89	0.88	0.80	7.2	2.2	2.5	68	0.302	235
37	50	225S	1480	66.1	50.3	92.9	93.0	92.2	0.87	0.86	0.80	7.2	2.2	2.5	68	0.538	290
45	60	225M	1480	80.0	61.0	93.3	93.3	92.6	0.87	0.85	0.80	7.2	2.2	2.5	68	0.635	326
55	75	250S/M	1480	95.0	72.4	93.9	93.7	92.6	0.89	0.87	0.81	7.2	2.2	2.5	69	0.785	385
75	100	280S	1485	132	101	94.1	94.0	92.9	0.87	0.85	0.79	7.2	2.2	2.5	70	1.552	515
90	125	280M	1485	158	121	94.3	94.0	93.3	0.87	0.85	0.79	7.2	2.2	2.5	70	1.865	605
110	150	315S	1485	190	145	94.8	94.2	92.5	0.88	0.84	0.76	6.9	2.1	2.2	74	3.48	931
132	175	315M	1485	228	174	94.9	94.3	92.9	0.88	0.85	0.78	6.9	2.1	2.2	74	3.678	1017
160	215	315M/L	1485	276	210	95.2	94.9	94.4	0.88	0.87	0.82	6.9	2.1	2.2	74	4.472	1085
200	270	315M/L	1485	345	263	95.2	94.9	93.7	0.88	0.87	0.82	6.9	2.1	2.2	76	4.856	1200
250	335	355M/L	1490	416	317	95.3	94.9	93.6	0.91	0.90	0.86	7.1	2.1	2.2	79	7.364	1740
280	375	355M/L	1490	474	361	95.8	95.2	94.0	0.89	0.87	0.82	6.9	2.1	2.2	80	8.014	1870
315	420	355M/L	1490	534	407	95.7	95.2	94.0	0.89	0.87	0.82	6.9	2.1	2.2	80	9.1	1975

IE2 efficiency class according to IEC60034-30;2008

Efficiency outside of IEC IE2 standard power range is according to Wonder specification.

Efficiency testing method is according to IEC60034-2-1;2007

WE SERIES PERFORMANCE DATA

IE2

TECHNICAL SPECIFICATIONS

Output		IEC Frame	Rated speed	Full load current I_n (A)		Efficiency η %			Power factor $\cos\phi$			Locked rotor current I_L/I_n	Locked rotor torque T_L/T_n	Break-down torque T_b/T_n	Sound LP dB(A)	Moment of inertia J(kg m^2)	Weight (kg)
KW	HP		(rpm)	400V	5 25V	100	75	50	100	75	50						
1000 min ⁻¹ (6poles) 50Hz																	
0.37	0.5	80	900	1.09	0.83	70.9	69.4	68.8	0.69	0.61	0.51	6.7	2.1	2.2	44	0.00194	18
0.55	0.75	80	905	1.55	1.18	74.1	72.8	68.7	0.69	0.60	0.52	6.7	2.2	2.3	45	0.00231	20
0.75	1	90S	920	2.03	1.55	76.0	75.5	73.8	0.70	0.62	0.50	7.5	2.2	2.2	45	0.00321	24
1.1	1.5	90L	920	2.90	2.21	78.3	77.5	75.9	0.70	0.63	0.51	7.7	2.5	2.6	45	0.00412	26
1.5	2	100L	925	3.82	2.91	79.8	78.1	77.8	0.71	0.64	0.55	7.0	2.8	2.9	46	0.00845	34
2.2	3	112M	925	5.39	4.11	81.8	81.7	80.4	0.72	0.70	0.56	7.2	2.2	2.8	46	0.01326	40
3	4	132S	950	6.93	5.28	83.3	83.2	82.2	0.75	0.71	0.58	7.5	2.2	2.5	50	0.03716	57
4	5.5	132M	950	8.86	6.75	84.6	84.1	83.6	0.77	0.70	0.58	7.2	2.7	2.8	50	0.04889	73
5.5	7.5	132M	960	12.0	9.13	86.0	86.0	85.4	0.77	0.71	0.60	7.4	2.8	2.9	53	0.05845	77
7.5	10	160M	970	15.9	12.1	87.4	87.4	86.2	0.78	0.71	0.59	6.5	2.0	2.3	56	0.1212	110
11	15	160L	970	22.9	17.4	88.9	88.9	87.8	0.78	0.72	0.60	6.4	2.0	2.3	56	0.1452	133
15	20	180L	975	29.7	22.7	89.9	89.9	88.5	0.81	0.76	0.66	7.0	2.0	2.3	56	0.2285	174
18.5	25	200L	980	36.4	27.8	90.5	90.6	89.6	0.81	0.77	0.68	7.0	2.1	2.4	59	0.342	219
22	30	200L	980	43.1	32.9	90.9	90.9	89.8	0.81	0.76	0.67	7.0	2.1	2.4	59	0.386	228
30	40	225M	980	56.2	42.8	91.8	91.8	90.9	0.84	0.81	0.74	7.0	2.0	2.3	61	0.625	296
37	50	250S/M	980	66.5	50.7	92.3	92.4	91.4	0.87	0.85	0.78	7.0	2.1	2.5	61	0.985	380
45	60	280S	985	81.4	62.0	92.8	92.7	91.7	0.86	0.84	0.78	7.0	2.1	2.5	66	1.7325	470
55	75	280M	985	99.0	75.5	93.2	93.2	92.3	0.86	0.85	0.80	7.0	2.1	2.5	66	1.965	545
75	100	315S	985	136	103	93.8	93.5	92.1	0.85	0.83	0.77	7.0	2.0	2.2	70	3.723	866
90	125	315M	985	162	124	94.2	93.7	92.3	0.85	0.83	0.75	7.0	2.0	2.2	70	4.526	948
110	150	315M/L	985	196	149	94.4	94.3	93.3	0.86	0.84	0.79	6.7	2.0	2.2	70	5.157	1120
132	175	315M/L	985	234	178	94.6	94.4	93.5	0.86	0.85	0.80	6.7	2.0	2.2	70	5.685	1185
160	215	355M/L	990	277	211	94.9	94.6	93.5	0.88	0.86	0.79	6.7	1.9	2.0	75	9.57	1705
180	240	355M/L	990	310	237	95.1	94.9	94.0	0.88	0.86	0.80	6.7	1.9	2.0	75	9.89	1785
200	270	355M/L	990	345	263	95.1	94.9	94.0	0.88	0.86	0.80	6.7	1.9	2.0	75	11.1	1890
225	300	355M/L	990	388	296	95.1	94.9	94.0	0.88	0.86	0.80	6.7	1.9	2.0	75	11.3	1950
250	335	355M/L	990	431	329	95.1	94.9	94.0	0.88	0.86	0.80	6.7	1.9	2.0	75	11.8	2000
280	375	355M/L	990	483	368	95.1	94.9	94.0	0.88	0.86	0.80	6.7	1.9	2.0	75	12.9	2080

IE2 efficiency class according to IEC60034-30;2008

Efficiency outside of IEC IE2 standard power range is according to Wonder specification.

Efficiency testing method is according to IEC60034-2-1;2007

WE SERIES PERFORMANCE DATA

TECHNICAL SPECIFICATIONS

Output		IEC Frame	Rated speed (rpm)	Full load current I_n (A)		Efficiency η %			Power factor $\cos\phi$			Locke d rotor current I_L/I_n	Locke d rotor torque T_L/T_n	Break-down torque T_b/T_n	Sound LP dB(A)	Moment of inertia J(kg m^2)	Weight (kg)
kW	HP			400V	525V	100	75	50	100	75	50						
750 min ⁻¹ (8poles) 50Hz																	
0.37	0.5	90S	710	1.30	0.99	70.8	68.9	66.7	0.58	0.53	0.48	6.5	2.0	2.0	45	0.0033	22
0.55	0.75	90L	710	1.89	1.44	71.3	69.5	67.8	0.59	0.54	0.50	6.5	2.0	2.0	45	0.0043	24
0.75	1	100L	715	2.42	1.84	73.3	72.1	71.7	0.61	0.57	0.53	6.8	2.0	2.1	47	0.0069	31
1.1	1.5	100L	720	3.39	2.58	75.5	75.1	74.6	0.62	0.58	0.57	7.0	2.0	2.1	47	0.0103	32
1.5	2	112M	720	4.24	3.23	77.3	77.0	75.3	0.66	0.62	0.58	7.0	2.0	2.1	49	0.013	38
2.2	3	132S	725	5.90	4.50	80.3	80.0	79.5	0.67	0.63	0.60	7.0	2.0	2.2	50	0.034	55
3.0	4	132M	725	7.78	5.92	81.9	81.6	80.8	0.68	0.66	0.64	7.2	2.2	2.3	50	0.042	71
4.0	5.5	160M	725	9.55	7.28	82.8	83.4	82.2	0.73	0.67	0.54	6.0	2.1	2.2	53	0.0889	98
5.5	7.5	160M	730	12.7	9.7	84.5	85.1	84.1	0.74	0.67	0.55	6.0	2.1	2.2	53	0.0958	109
7.5	10	160L	730	17.0	13.0	86.0	86.6	85.7	0.74	0.67	0.55	6.0	2.0	2.2	53	0.1021	131
11	15	180L	730	24.5	18.6	87.7	87.9	86.5	0.74	0.68	0.56	6.6	2.0	2.3	53	0.2275	173
15	20	200L	735	32.5	24.7	88.9	89.0	87.7	0.75	0.69	0.57	6.6	2.0	2.3	55	0.395	234
18.5	25	225S	735	39.2	29.8	89.7	89.9	88.8	0.76	0.70	0.59	6.6	1.9	2.0	55	0.603	276
22	30	225M	735	46.3	35.3	90.2	90.3	89.3	0.76	0.70	0.59	6.6	1.9	2.0	55	0.698	298
30	40	250S/M	735	60.1	45.8	91.2	91.4	90.7	0.79	0.75	0.64	6.6	1.9	2.0	58	0.983	375
37	50	280S	735	73.6	56.1	91.8	91.9	91.0	0.79	0.75	0.65	6.6	1.9	2.2	58	1.857	480
45	60	280M	735	89.0	67.8	92.4	92.6	91.9	0.79	0.76	0.67	6.6	1.9	2.2	58	1.998	560
55	75	315S	740	106	80.4	92.9	92.6	91.2	0.81	0.77	0.67	6.6	1.8	2.0	63	4.959	915
75	100	315M	740	143	109	93.7	93.4	92.2	0.81	0.77	0.67	6.6	1.8	2.0	63	5.825	991
90	125	315M/L	740	168	128	94.1	93.8	92.6	0.82	0.78	0.67	6.6	1.8	2.0	63	6.753	1083
110	150	315M/L	740	205	156	94.5	94.1	92.8	0.82	0.77	0.67	6.4	1.8	2.0	63	7.352	1174
132	175	355M/L	745	245	187	94.8	94.5	93.4	0.82	0.79	0.70	6.4	1.8	2.0	70	12.94	1815
160	215	355M/L	745	296	225	95.2	94.9	93.7	0.82	0.78	0.69	6.4	1.8	2.0	70	13.32	1905
180	240	355M/L	745	333	254	95.2	94.9	93.8	0.82	0.79	0.69	6.4	1.8	2.0	70	14.0	1985
200	270	355M/L	745	370	282	95.2	94.9	93.8	0.82	0.79	0.69	6.4	1.8	2.0	70	14.9	2060

IE2 efficiency class according to IEC60034-30;2008

Efficiency outside of IEC IE2 standard power range is according to Wonder specification.

Efficiency testing method is according to IEC60034-2-1;2007

B3 MOUNTING AND OVERALL DIMENSIONS

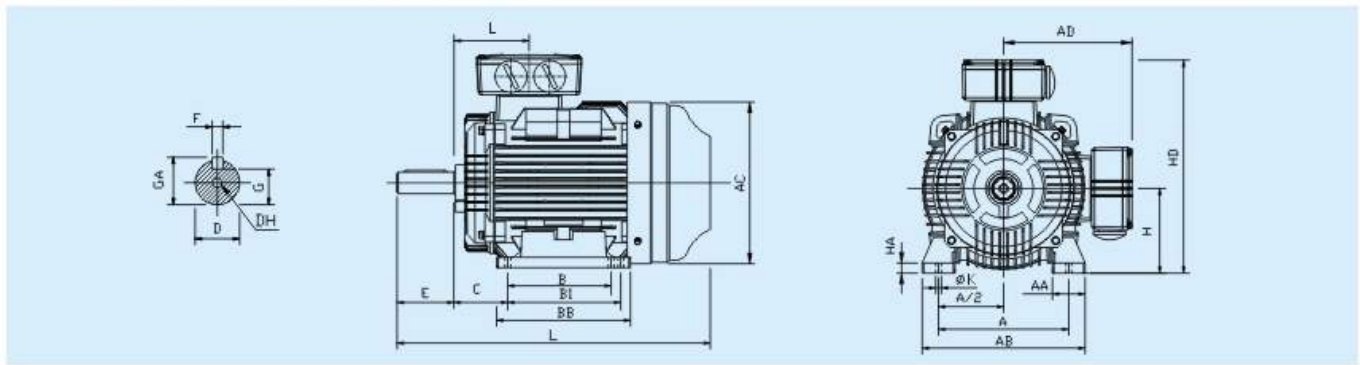

Frame size	Poles	Mounting dimensions(mm)												Overall dimensions(mm)								
		A	B	B1	C	D	E	F	G	H	K	DH	GA	AA	AB	AC	AD	HA	HD	BB	LD	L
80	2,4,6	125	100	/	50	19	40	6	15.5	80	10	M6x16	21.5	35	160	165	145	12	235	135	75	310
90S	2,4,6	140	100	/	56	24	50	8	20	90	10	M8x20	27	36	174	180	155	12	245	130	75	320
90L	2,4,6,8	140	125	/	56	24	50	8	20	90	10	M8x20	27	36	174	180	155	12	245	155	75	345
100L	2,4,6,8	160	140	/	63	28	60	8	24	100	12	M10x25	31	40	200	220	190	14	269	179	83	388
112M	2,4,6,8	190	140	/	70	28	60	8	24	112	12	M10x25	31	45	235	220	190	15	305	180	87	390
132S	2,4,6,8	216	140	/	89	38	80	10	33	132	12	M12x30	41	55	270	260	220	18	339	182	102	462
132M	2,4,6,8	216	178	/	89	38	80	10	33	132	12	M12x30	41	55	265	260	220	18	339	220	102	500
160M	2~8	254	210	/	108	42	110	12	37	160	15	M16x36	45	65	315	315	265	20	409	260	146	614
160L	2~8	254	254	/	108	42	110	12	37	160	15	M16x36	45	65	315	315	265	20	409	384	146	658
180M	2,4	279	241	/	121	48	110	14	42.5	180	15	M16x36	51.5	70	350	360	280	22	445	311	161	690
180L	4,6,8	279	279	/	121	48	110	14	42.5	180	15	M16x36	51.5	70	350	360	280	22	445	349	161	728
200L	2~8	318	305	/	133	55	110	16	49	200	19	M20x42	59	70	388	400	310	25	492	370	186	780
225S	4,8	356	286	/	149	60	140	18	53	225	19	M20x42	64	75	435	450	335	28	540	361	189	825
225M	2	356	311	/	149	55	110	16	49	225	19	M20x42	59	75	435	450	335	28	540	386	189	820
	4~8	356	311	/	149	60	140	18	53	225	19	M20x42	64	75	435	450	335	28	540	386	189	850
250S,M	2	406	349	311	168	60	140	18	53	250	24	M20x42	64	80	503	485	375	30	616	445	207	915
	4~8	406	349	311	168	65	140	18	58	250	24	M20x42	69	80	503	485	375	30	616	445	207	915
280S	2	457	368	/	190	65	140	18	58	280	24	M20x42	69	85	545	550	405	35	672	490	215	968
	4~8	457	368	/	190	75	140	20	67.5	280	24	M20x42	79.5	85	545	550	405	35	672	490	215	968
280M	2	457	419	/	190	65	140	18	58	280	24	M20x42	69	85	545	550	405	35	672	540	215	1020
	4~8	457	419	/	190	75	140	20	67.5	280	24	M20x42	79.5	85	545	550	405	35	672	540	215	1020
315S	2	508	406	/	216	65	140	18	58	315	28	M20x46	69	120	630	625	530	45	815	570	257	1204
	4~8	508	406	/	216	80	170	22	71	315	28	M20x46	85	120	630	625	530	45	815	570	257	1234
315M,L	2	508	457	508	216	65	140	18	58	315	28	M20x46	69	120	630	625	530	45	815	680	257	1307
	4~8	508	457	508	216	80	170	22	71	315	28	M20x46	85	120	630	625	530	45	815	680	257	1337
355M,L	2	610	560	630	254	75	140	20	67.5	355	28	M20x46	79.5	120	730	710	615	52	970	750	284	1526
	4~8	610	560	630	254	95	170	25	86	355	28	M24x56	100	120	730	710	615	52	970	750	284	1556

B35 MOUNTING AND OVERALL DIMENSIONS

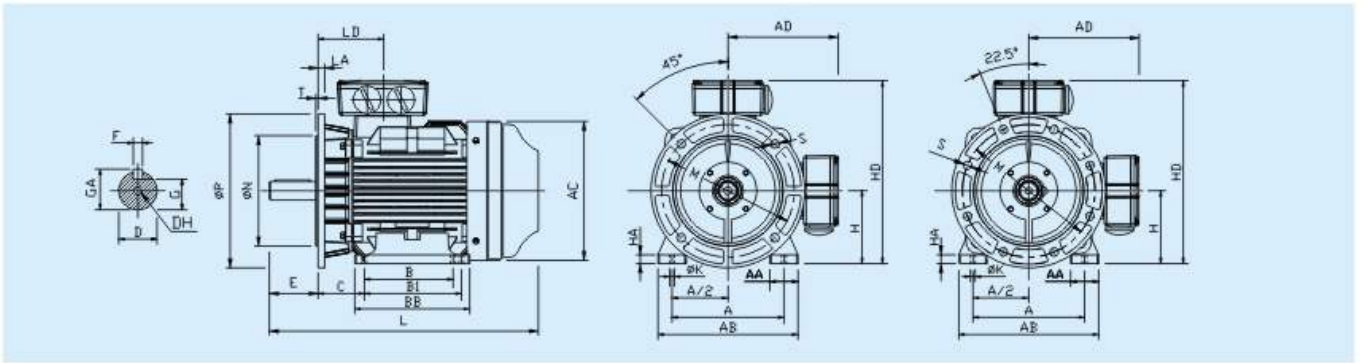

Frame size	Poles	Mounting dimensions(mm)																Overall dimensions(mm)										
		A	B	B1	C	D	E	F	G	H	K	M	N	P	S	T	DH	GA	AA	AB	AC	AD	BB	HA	HD	LA	LD	L
80	2~6	125	100	/	50	19	40	6	15.5	80	10	165	130	200	4-φ12	4	M6x16	21.5	35	160	165	145	130	12	235	12	75	310
90S	2~6	140	100	/	56	24	50	8	20	90	10	165	130	200	4-φ12	4	M8x20	27	36	180	175	155	140	12	245	12	75	320
90L	2~6	140	125	/	56	24	50	8	20	90	10	165	130	200	4-φ12	4	M8x20	27	36	180	175	155	165	12	245	12	75	345
100L	2~6	160	140	/	63	28	60	8	24	100	12	215	180	250	4-φ15	4	M10x25	31	40	200	220	190	175	14	295	13	83	388
112M	2~6	190	140	/	70	28	60	8	24	112	12	215	180	250	4-φ15	4	M10x25	31	45	230	220	190	180	15	305	14	87	390
132S	2~6	216	140	/	89	38	80	10	33	132	12	265	230	300	4-φ15	4	M12x30	41	55	265	260	220	190	18	355	14	102	462
132M	2~6	216	178	/	89	38	80	10	33	132	12	265	230	300	4-φ15	4	M12x30	41	55	265	260	220	230	18	355	14	102	500
160M	2~8	254	210	/	108	42	110	12	37	160	15	300	250	350	4-φ19	5	M16x36	45	65	315	315	265	260	20	425	15	146	614
160L	2~8	254	254	/	108	42	110	12	37	160	15	300	250	350	4-φ19	5	M16x36	45	65	315	315	265	305	20	425	15	146	658
180M	2	279	241	/	121	48	110	14	42.5	180	15	300	250	350	4-φ19	5	M16x36	51.5	70	350	360	280	315	22	460	15	161	690
180L	4~8	279	279	/	121	48	110	14	42.5	180	15	300	250	350	4-φ19	5	M16x36	51.5	70	350	360	280	350	22	460	15	161	728
200L	2~8	318	305	/	133	55	110	16	49	200	19	350	300	400	4-φ19	5	M20x42	59	70	390	400	310	370	25	510	17	186	780
225S	4~8	356	286	/	149	60	140	18	53	225	19	400	350	450	8-φ19	5	M20x42	64	75	435	450	335	370	28	555	20	189	825
225M	2	356	311	/	149	55	110	16	49	225	19	400	350	450	8-φ19	5	M20x42	59	75	435	450	335	395	28	555	20	189	820
	4~8	356	311	/	149	60	140	18	53	225	19	400	350	450	8-φ19	5	M20x42	64	75	435	450	335	395	28	555	20	189	850
250M	2	406	349	311	168	60	140	18	53	250	24	500	450	550	8-φ19	5	M20x42	64	80	485	490	375	445	30	625	22	207	915
	4~8	406	349	311	168	65	140	18	58	250	24	500	450	550	8-φ19	5	M20x42	69	80	485	490	375	445	30	625	22	207	915
280S	2	457	368	/	190	65	140	18	58	280	24	500	450	550	8-φ19	5	M20x42	69	85	545	550	405	490	35	685	22	215	968
	4~8	457	368	/	190	75	140	20	67.5	280	24	500	450	550	8-φ19	5	M20x42	79.5	85	545	550	405	490	35	685	22	215	968
280M	2	457	419	/	190	65	140	18	58	280	24	500	450	550	8-φ19	5	M20x42	69	85	545	550	405	540	35	685	22	215	1020
	4~8	457	419	/	190	75	140	20	67.5	280	24	500	450	550	8-φ19	5	M20x42	79.5	85	545	550	405	540	35	685	22	215	1020
315S	2	508	406	/	216	65	140	18	58	315	28	600	550	660	8-φ24	6	M20x46	69	120	630	625	530	570	45	845	22	257	1180
	4~8	508	406	/	216	80	170	22	71	315	28	600	550	660	8-φ24	6	M20x46	85	120	630	625	530	570	45	845	22	257	1210
315M,L	2	508	457	508	216	65	140	18	58	315	28	600	550	660	8-φ24	6	M20x46	69	120	630	625	530	680	45	845	22	257	1290
	4~8	508	457	508	216	80	170	22	71	315	28	600	550	660	8-φ24	6	M20x46	85	120	630	625	530	680	45	845	22	257	1320
355M,L	2	610	500	630	254	75	140	20	67.5	355	28	740	680	800	8-φ24	6	M20x46	79.5	120	730	710	615	750	52	970	25	284	1526
	4~8	610	500	630	254	95	170	25	86	355	28	740	680	800	8-φ24	6	M20x46	100	120	730	710	615	750	52	970	25	284	1556

R=0 distance from flange to shaft shoulder

B5 MOUNTING AND OVERALL DIMENSIONS

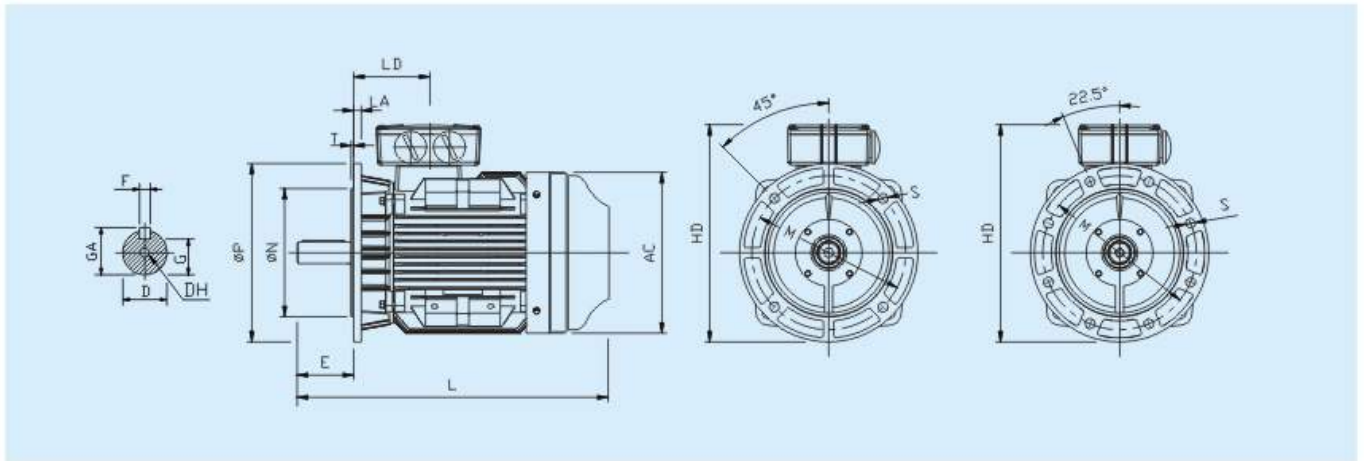

Frame size	Poles	Mounting dimensions(mm)										Overall dimensions(mm)					
		D	E	F	G	M	N	P	S	T	DH	GA	AC	HD	LA	LD	L
80	2,4,6	19	40	6	15.5	165	130	200	4- ϕ 12	3.5	M6x16	21.5	165	243	12	75	310
90S	2,4,6	24	50	8	20	165	130	200	4- ϕ 12	3.5	M8x20	27	180	257	12	75	320
90L	2,4,6	24	50	8	20	165	130	200	4- ϕ 12	3.5	M8x20	27	180	257	12	75	345
100L	2,4,6	28	60	8	24	215	180	250	4- ϕ 15	4	M10x25	31	220	294	13	83	388
112M	2,4,6	28	60	8	24	215	180	250	4- ϕ 15	4	M10x25	31	220	317	14	87	390
132S	2,4,6	38	80	10	33	265	230	300	4- ϕ 15	4	M12x30	41	260	357	14	102	462
132M	2,4,6	38	80	10	33	265	230	300	4- ϕ 15	4	M12x30	41	260	357	14	102	490
160M	2~8	42	110	12	37	300	250	350	4- ϕ 19	5	M16x36	45	315	424	15	146	614
160L	2~8	42	110	12	37	300	250	350	4- ϕ 19	5	M16x36	45	315	424	15	146	658
180M	2,4	48	110	14	42.5	300	250	350	4- ϕ 19	5	M16x36	51.5	360	440	15	161	690
180L	4,6,8	48	110	14	42.5	300	250	350	4- ϕ 19	5	M16x36	51.5	360	440	15	161	728
200L	2~8	55	110	16	49	350	300	400	4- ϕ 19	5	M20x42	59	400	492	17	186	780
225S	4,8	60	140	18	53	400	350	450	8- ϕ 19	5	M20x42	64	450	540	20	189	825
225M	2	55	110	16	49	400	350	450	8- ϕ 19	5	M20x42	59	450	540	20	189	820
	4~8	60	140	18	53	400	350	450	8- ϕ 19	5	M20x42	64	450	540	20	189	850
250S,M	2	60	140	18	53	500	450	550	8- ϕ 19	5	M20x42	64	485	639	22	207	915
	4~8	65	140	18	58	500	450	550	8- ϕ 19	5	M20x42	69	485	639	22	207	915
280S	2	65	140	18	58	500	450	550	8- ϕ 19	5	M20x42	69	550	685	22	215	968
	4~8	75	140	20	67.5	500	450	550	8- ϕ 19	5	M20x42	79.5	550	685	22	215	968
280M	2	65	140	18	58	500	450	550	8- ϕ 19	5	M20x42	69	550	685	22	215	1020
	4~8	75	140	20	67.5	500	450	550	8- ϕ 19	5	M20x42	79.5	550	685	22	215	1020

R=0 distance from flange to shaft shoulder

VI MOUNTING AND OVERALL DIMENSIONS

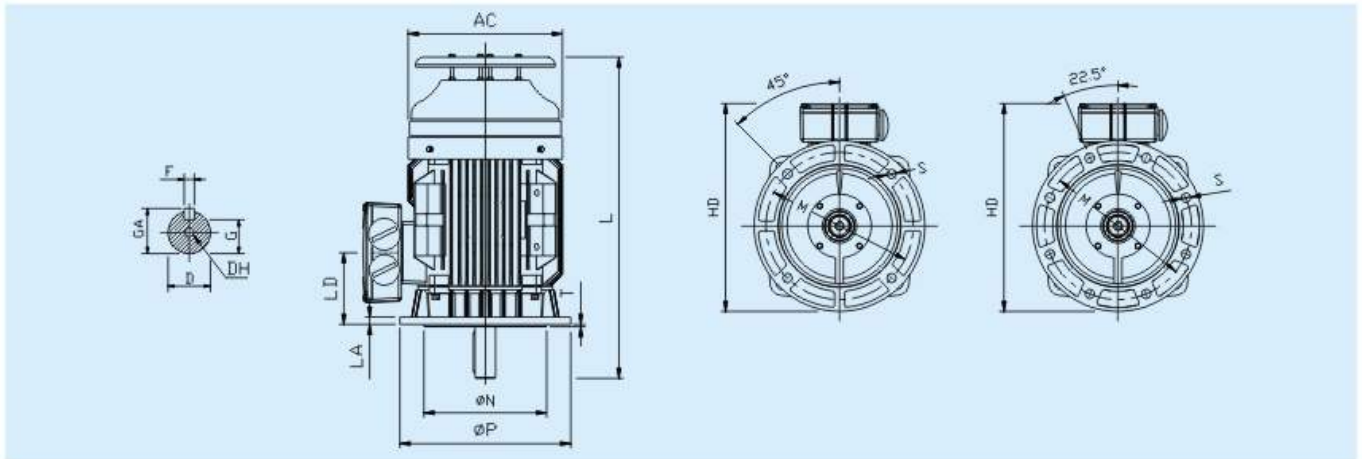

Frame size	Poles	Mounting dimensions(mm)										Overall dimensions(mm)					
		D	E	F	G	M	N	P	S	T	DH	GA	AC	LA	HD	LD	L
80	2~6	19	40	6	15.5	165	130	200	4-φ12	3.5	M6x16	21.5	165	12	243	75	349
90S	2~6	24	50	8	20	165	130	200	4-φ12	3.5	M8x20	27	175	12	257	75	362
90L	2~6	24	50	8	20	165	130	200	4-φ12	3.5	M8x20	27	175	12	257	75	387
100L	2~6	28	60	8	24	215	180	250	4-φ15	4	M10x25	31	220	13	294	83	428
112M	2~6	28	60	8	24	215	180	250	4-φ15	4	M10x25	31	225	14	317	87	436
132S	2~6	38	80	10	33	265	230	300	4-φ15	4	M12x30	41	260	14	357	102	508
132M	2~6	38	80	10	33	265	230	300	4-φ15	4	M12x30	41	260	14	357	102	538
160M	2~8	42	110	12	37	300	250	350	4-φ19	5	M16x36	45	315	15	424	146	660
160L	2~8	42	110	12	37	300	250	350	4-φ19	5	M16x36	45	315	15	424	146	704
180M	2.4	48	110	14	42.5	300	250	350	4-φ19	5	M16x36	51.5	360	15	440	161	744
180L	4~8	48	110	14	42.5	300	250	350	4-φ19	5	M16x36	51.5	360	15	440	161	782
200L	2~8	55	110	16	49	350	300	400	4-φ19	5	M20x42	59	400	17	492	186	849
225S	4.8	60	140	18	53	400	350	450	8-φ19	5	M20x42	64	450	20	540	189	911
225M	2	55	110	16	49	400	350	450	8-φ19	5	M20x42	59	450	20	540	189	895
	4~8	60	140	18	53	400	350	450	8-φ19	5	M20x42	64	450	20	540	189	935
250S,M	2	60	140	18	53	500	450	550	8-φ19	5	M20x42	64	490	22	639	207	1010
	4~8	65	140	18	58	500	450	550	8-φ19	5	M20x42	69	490	22	639	207	1010
280S	2	65	140	18	58	500	450	550	8-φ19	5	M20x42	69	550	22	685	215	1082
	4~8	75	140	20	67.5	500	450	550	8-φ19	5	M20x42	79.5	550	22	685	215	1080
280M	2	65	140	18	58	500	450	550	8-φ19	5	M20x42	69	550	22	685	215	1133
	4~8	75	140	20	67.5	500	450	550	8-φ19	5	M20x42	79.5	550	22	685	215	1131
315S	2	65	140	18	58	600	550	660	8-φ24	6	M20x46	69	625	22	845	257	1324
	4~8	80	170	22	71	600	550	660	8-φ24	6	M20x46	85	625	22	845	257	1354
315M,L	2	65	140	18	58	600	550	660	8-φ24	6	M20x46	69	625	22	845	257	1427
	4~8	80	170	22	71	600	550	660	8-φ24	6	M20x46	85	625	22	845	257	1457
355M,L	2	75	140	20	67.5	740	680	800	8-φ24	6	M20x46	79.5	710	25	970	284	1665
	4~8	95	170	25	86	740	680	800	8-φ24	6	M24x56	100	710	25	970	284	1700

B34 MOUNTING AND OVERALL DIMENSIONS

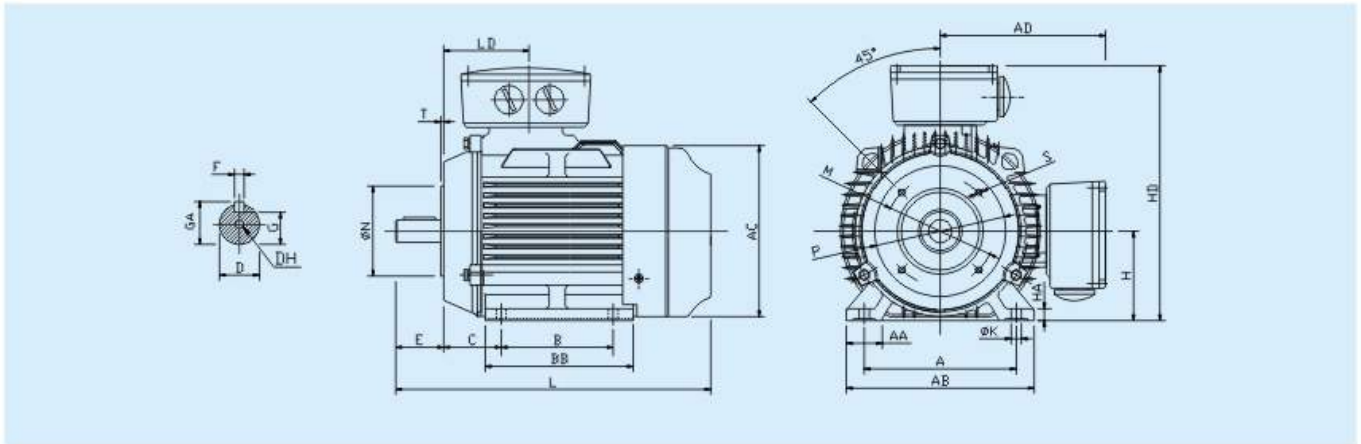

B34A

Frame size	Mounting dimensions(mm)														Overall dimensions(mm)										
	A	B	C	D	E	F	G	H	K	M	N	P	S	T	DH	GA	AA	AB	AC	AD	BB	HA	HD	LD	L
80	125	100	50	19	40	6	15.5	80	10	100	80	120	4-M6	3	M6x16	21.5	35	160	165	145	130	12	235	75	310
90S	140	100	56	24	50	8	20	90	10	115	95	140	4-M8	3	M8x20	27	36	180	180	155	140	12	245	75	320
90L	140	125	56	24	50	8	20	90	10	115	95	140	4-M8	3	M8x20	27	36	180	180	155	165	12	245	75	345
100L	160	140	63	28	60	8	24	100	12	130	110	160	4-M8	3.5	M10x25	31	40	200	220	190	175	14	295	83	388
112M	190	140	70	28	60	8	24	112	12	130	110	160	4-M8	3.5	M10x25	31	45	230	220	190	180	15	305	87	390
132S	216	140	89	38	80	10	33	132	12	165	130	200	4-M10	4	M12x30	41	55	265	260	220	190	18	355	102	462
132M	216	178	89	38	80	10	33	132	12	165	130	200	4-M10	4	M12x30	41	55	265	260	220	230	18	355	102	500

R=0 distance from flange to shaft shoulder

B34B

Frame size	Mounting dimensions(mm)														Overall dimensions(mm)										
	A	B	C	D	E	F	G	H	K	M	N	P	S	T	DH	GA	AA	AB	AC	AD	BB	HA	HD	LD	L
80	125	100	50	19	40	6	15.5	80	10	130	110	160	4-M8	3	M6x16	21.5	35	160	160	145	130	12	225	75	310
90S	140	100	56	24	50	8	20	90	10	130	110	160	4-M8	3	M8x20	27	36	180	180	155	140	12	245	75	320
90L	140	125	56	24	50	8	20	90	10	130	110	160	4-M8	3	M8x20	27	36	180	180	155	165	12	245	75	345
100L	160	140	63	28	60	8	24	100	12	165	130	200	4-M10	3.5	M10x25	31	40	200	220	190	175	14	295	83	388
112M	190	140	70	28	60	8	24	112	12	165	130	200	4-M10	3.5	M10x25	31	45	230	220	190	180	15	305	87	390
132S	216	140	89	38	80	10	33	132	12	215	180	250	4-M12	4	M12x30	41	55	265	260	220	190	18	355	102	462
132M	216	178	89	38	80	10	33	132	12	215	180	250	4-M12	4	M12x30	41	55	265	260	220	230	18	355	102	500

R=0 distance from flange to shaft shoulder

B14 MOUNTING AND OVERALL DIMENSIONS

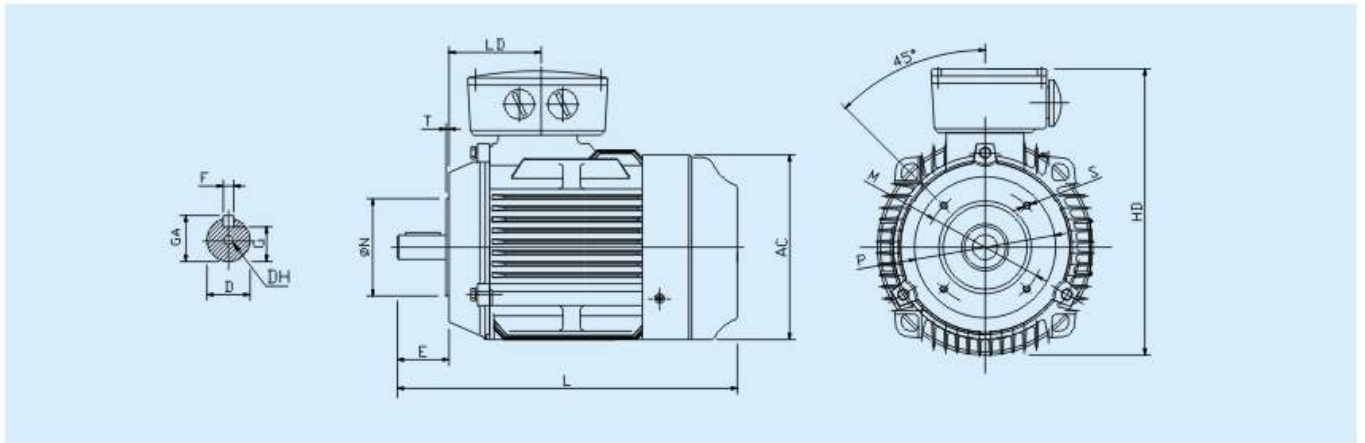

B14A MOUNTING AND OVERALL DIMENSIONS

Frame size	Mounting dimensions(mm)										Overall dimensions(mm)				
	D	E	F	G	M	N	P	S	T	DH	GA	AC	HD	LD	L
80	19	40	6	15.5	100	80	120	4-M6	3	M6x16	21.5	165	235	75	310
90S	24	50	8	20	115	95	140	4-M8	3	M8x20	27	180	245	75	320
90L	24	50	8	20	115	95	140	4-M8	3	M8x20	27	180	245	75	345
100L	28	60	8	24	130	110	160	4-M8	3.5	M10x25	31	220	295	83	388
112M	28	60	8	24	130	110	160	4-M8	3.5	M10x25	31	220	305	87	390
132S	38	80	10	33	165	130	200	4-M10	4	M12x30	41	260	365	102	462
132M	38	80	10	33	165	130	200	4-M10	4	M12x30	41	260	365	102	500

R=0 distance from flange to shaft shoulder

B14B MOUNTING AND OVERALL DIMENSIONS

Frame size	Mounting dimensions(mm)										Overall dimensions(mm)				
	D	E	F	G	M	N	P	S	T	DH	GA	AC	HD	LD	L
80	19	40	6	15.5	130	110	160	4-M8	3.5	M6x16	21.5	165	235	75	310
90S	24	50	8	20	130	110	160	4-M8	3.5	M8x20	27	180	245	75	320
90L	24	50	8	20	130	110	160	4-M8	3.5	M8x20	27	180	245	75	345
100L	28	60	8	24	165	130	200	4-M10	3.5	M10x25	31	220	295	83	388
112M	28	60	8	24	165	130	200	4-M10	3.5	M10x25	31	220	305	87	390
132S	38	80	10	33	215	180	250	4-M12	4	M12x30	41	260	365	102	462
132M	38	80	10	33	215	180	250	4-M12	4	M12x30	41	260	365	102	500

R=0 distance from flange to shaft shoulder

TERMINAL BOX

Frame size	thread of cable gland (mm)	Overall dimensions(mm)
80-100	1-M25x1.5	124x100x50
112-132	1-M32x1.5	150x124x60
160-180	2-M40x1.5	200x160x80
200-225	2-M50x1.5	250x200x92
250-280	2-M63x1.5	340x210x106
315	2-M63x1.5	413x258x165
355	2-M63x1.5	461x300x190

BEARINGS

Frame size	Driving End		Non-driving End	
	2 pole	4, 6, 8 pole	2 pole	4, 6, 8 pole
80	6205 2Z/C3	6205 2Z/C3	6205 2Z/C3	6205 2Z/C3
90	6206 2Z/C3	6206 2Z/C3	6206 2Z/C3	6206 2Z/C3
100	6206 2Z/C3	6206 2Z/C3	6206 2Z/C3	6206 2Z/C3
112	6207 2Z/C3	6207 2Z/C3	6207 2Z/C3	6207 2Z/C3
132	6208 2Z/C3	6208 2Z/C3	6208 2Z/C3	6208 2Z/C3
160	6209 2Z/C3	6209 2Z/C3	6209 2Z/C3	6209 2Z/C3
180	6211/C3	6311/C3	6211/C3	6211/C3
200	6212/C3	6312/C3	6212/C3	6212/C3
225	6312/C3	6313/C3	6312/C3	6312/C3
250	6313/C3	6314/C3	6313/C3	6313/C3
280	6314/C3	6317/C3	6314/C3	6314/C3
315	6317/C3	Nu319	6317C3/7317B(V1)	6319C3/7319B(V1)
355	6319/C3	Nu322	6319C3/7319B(V1)	6322/7322B(V1)

The above motors can be load directly .
In case of high radial force, NU bearings are recommended.

MOTOR SPARE PART LIST/DRAWING

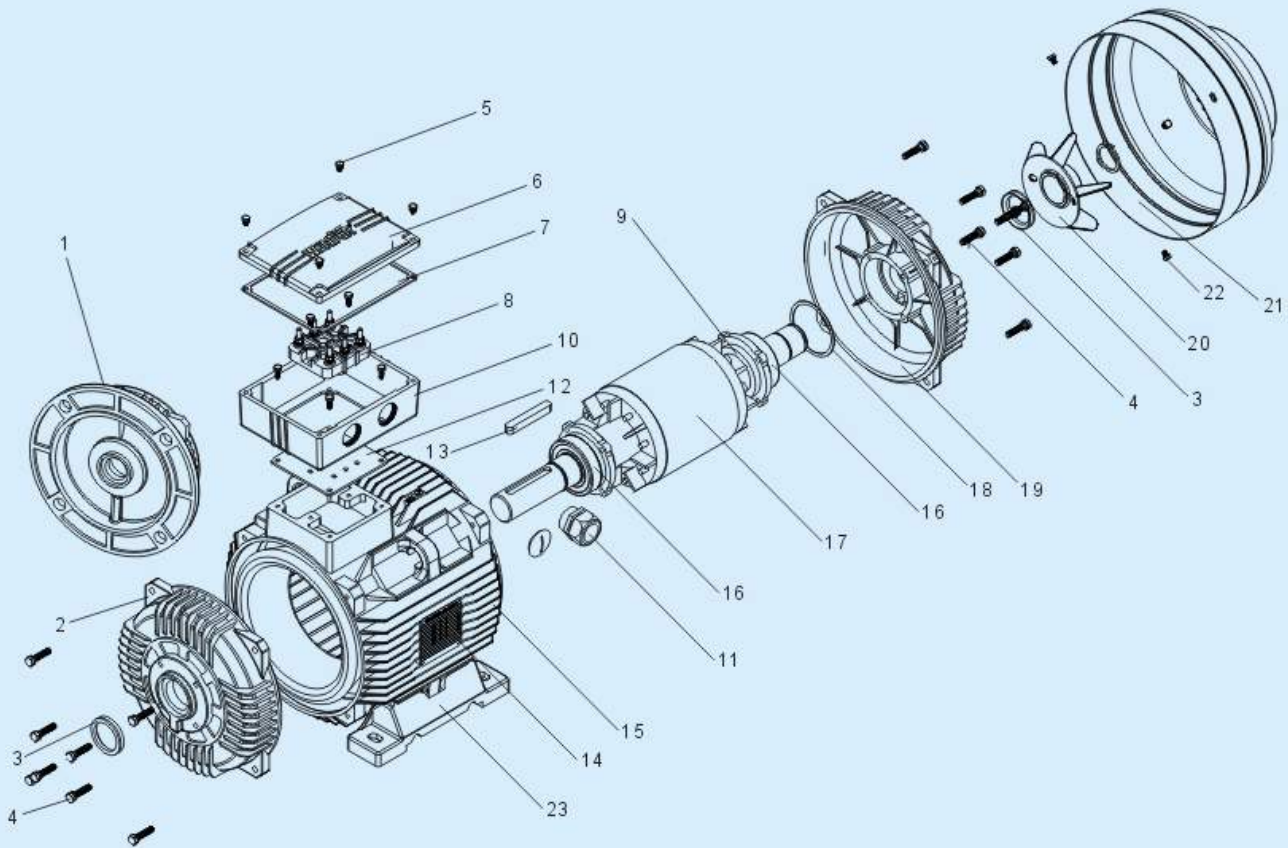

1.This catalogue is only a reference for users. The data may be changed, please contact us before ,ordering.

2.Note type, rated output, synchronous speed, voltage and frequency, insulation class ,mounting type etc. When ordering.

3.For special requirement, please contact us, we may deliver following special type of motor:

- (1)Voltage: such as 420V.
- (2)Frequency 60Hz.
- (3)Duble end shaft.
- (4)motor for tropical humid climate.

- 1.Flange B5
- 2.End shield B3
- 3.V-ring
- 4.Screws for fixing end shield
- 5.Screws for fixing terminal box cover
- 6.Terminal box cover IP55
- 7.Terminal box seal
- 8.Terminal board complete with components
- 9.bearing cover
- 10.Terminal box base
- 11.Cable gland and plug
- 12.Terminal base seal
- 13.Key
- 14.Name plate
- 15.Frame
- 16.Bearings
- 17.Rotor with shaft complete
- 18.Spring washer
- 19.NDE shield
- 20.Cooling fan
- 21.Fan cover
- 22.Screws for fixing fan cover
- 23.Feet