



M/1553
3/2 poppet valves, mechanically actuated
M5

Extremely compact trip and detector valves
Very light operating forces
Substantially non-corrodible construction
Manual versions also available on request



Technical features

Medium:

Compressed air, filtered, lubricated and non-lubricated

Operation:

Poppet valves, directly actuated

Operating pressure:

2 ... 10 bar

Port size:

M5

Fluid/Ambient temperature:

-20°C ... +80°C

Air supply must be dry enough to avoid ice formation at temperatures below +2°C.

Materials

Body: plastic

Roller operator: plastic

Plunger: brass

Seals: nitrile

Technical data

Symbol	Port size	Function	Operator/return	Operating pressure (bar)	Operating force at 6 bar (N)	Flow (l/min)	Cv	Weight (kg)	Drawing No.	Model
	M5	3/2	Plunger/spring	2 ... 10	5	59	0,06	0,010	1	M/1553/14
	M5	3/2	Roller/spring	2 ... 10	14	59	0,06	0,014	2	M/1553/8

Dimensions

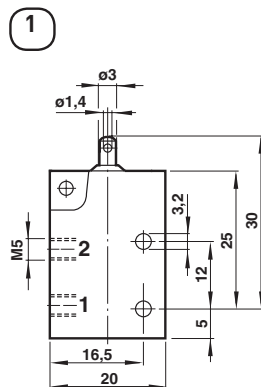

Pre-travel: 1,0 mm
 Operating Travel: 1,0 mm
 Over-travel: 1,0 mm

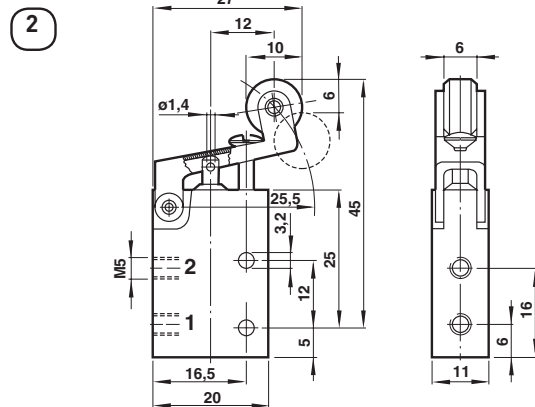

Pre-travel: 2,5 mm
 Operating Travel: 2,5 mm
 Over-travel: 2,5 mm

Warning

These products are intended for use in industrial compressed air systems only. Do not use these products where pressures and temperatures can exceed those listed under **'Technical features'**.

Before using these products with fluids other than those specified, for non-industrial applications, life-support systems, or other applications not within published specifications, consult NORGREN.

Through misuse, age, or malfunction, components used in fluid power systems can fail in various modes.

The system designer is warned to consider the failure modes of all component parts used in fluid power systems and to provide adequate safeguards to prevent personal injury or damage to equipment in the event of such failure.

System designers must provide a warning to end users in the system instructional manual if protection against a failure mode cannot be adequately provided.

System designers and end users are cautioned to review specific warnings found in instruction sheets packed and shipped with these products.